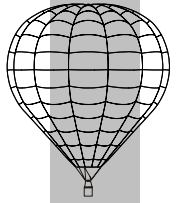

ULTRAMAGIC MK21 BURNER, BUTANE FUEL VARIANT**M
K
2
1
B
U
R
N
E
,
B
U
T
A
N
E
F
U
E
L
V
A
R
I
A
N
T****Section 1****1.0 Introduction**

This supplement defines the maintenance and inspection requirements for the range of Ultramagic MK 21 burners when configured for use with butane fuel.

Sections 1 to 5 detail the maintenance procedures and the parts used. Section 6 details the annual / 100 hour inspection and test requirements.

The burner when configured for use with butane fuel uses many common components to the standard MK21 burner already detailed in the Maintenance Manual. Only those areas which are different to those already detailed in the Maintenance Manual, are described in this supplement. All other limitations, instructions and safety information contained in the Maintenance Manual remain applicable.

1.1 Applicability

The information contained in this supplement applies to the Ultramagic range of MK 21 burners, when configured for use with butane fuel, as defined by the following drawing numbers:

Single Burner:	2021/0000
Double Burner:	2022/0000
Triple Burner:	2023/0000
Quad Burner:	2024/0000

1.2 Replacement Parts and Procedures

See Maintenance Manual.

1.3 Approved Maintenance and Inspection Personnel

See Maintenance Manual.

1.4 Welding and Welders

See Maintenance Manual.

1.5 Maintenance Records

See Maintenance Manual

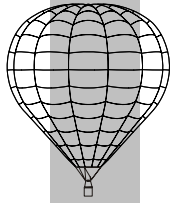

1.6 Technical Support

See Maintenance Manual.

1.7 Safety

The following safety instructions are additional to those already contained in the Maintenance Manual:

- Before initiating any maintenance work on the burner, ensure that the burner is fully vented of fuel and that it is disconnected from any fuel supply.

Section 2

2.0 Airworthiness Limitations

2.1 Approval Statement

This supplement provides the maintenance information for the MK21 burner when configured for use with butane fuel, as required by EASA CS 31 HB.82 and FAR 31 section 31.82.

2.2 Mandatory Replacement Time

See Maintenance Manual.

2.3 Inspection Interval

See Maintenance Manual.

Additional inspection requirements for the MK21 burner when configured for use with butane fuel are defined in Section 6 of this Supplement.

Section 3

3.0 Technical Description

3.1 General

Although similar in calorific content, propane and butane fuels have different characteristics, most noticeably the lower natural vapour pressure of butane when compared to propane at similar temperatures. This combined with certain other

differences require that the MK21 burner be configured differently when using butane to the standard propane configuration.

Since the natural vapour pressure of butane is significantly lower than that of propane at similar temperatures, it is normal to pressurise the fuel cylinder when using butane to achieve adequate fuel flow rates and thus burner output power. Pressurisation may be achieved by adding pressurised nitrogen gas to the fuel cylinder or by pre-heating the fuel cylinder with a purpose designed heater jacket. Either method of cylinder pressurisation requires a great degree of care. Procedures covering the methods of cylinder pressurisation are outside the scope of this document.

The differences between the burner in standard (propane) and butane configurations are restricted to two areas. A special Check Valve device is fitted at the burner fuel inlet just behind the Fuel Inlet Post and a different jet configuration is fitted in the Vapourisation Coil. Since propane fuel must not be used with a butane configured burner, one of the burner handle posts is engraved with the word "BUTANE" to act as identification.

The two methods of pressurising the cylinders (nitrogen and cylinder heating) result in different fuel characteristics. To account for this, different Check Valve parts are required. If replacement Check Valve parts are required, consult Ultramagic.

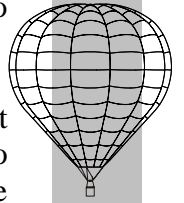

**M
K
2
1

B
U
R
N
E
R

B
U
T
A
N
E

F
U
E
L

V
A
R
I
A
N
T**

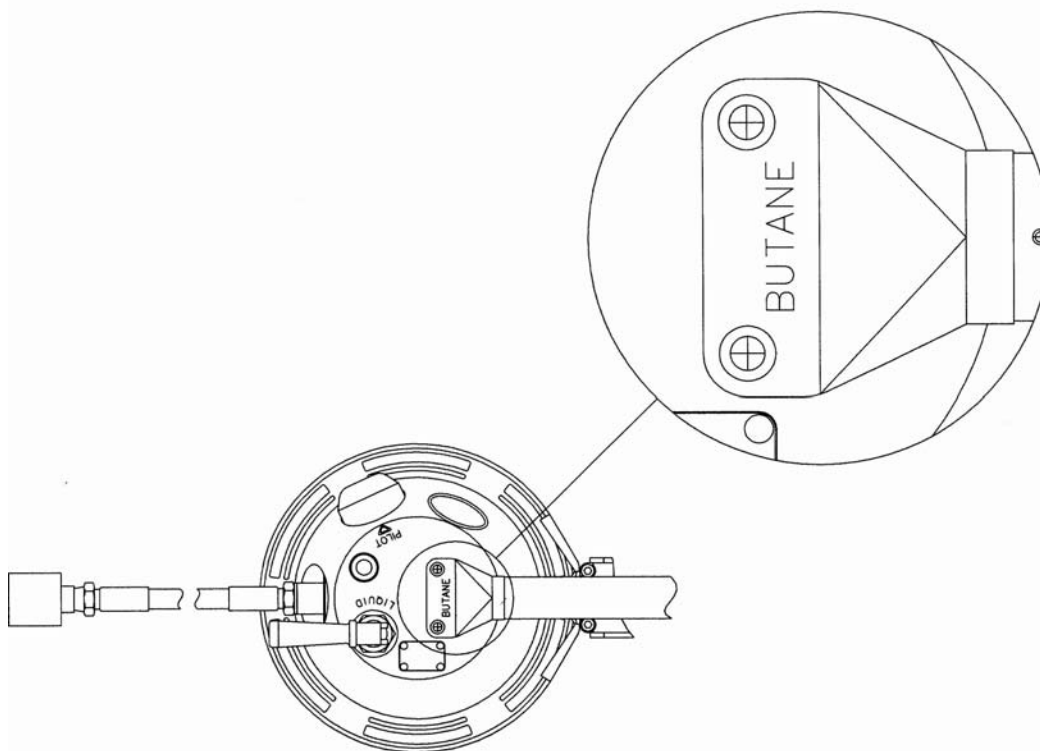

Fig 1 Showing "BUTANE" Identification

4 Preventative Maintenance

4.1 General

See Maintenance Manual.

Section 5

5 Repair and Maintenance

5.1 General

This section describes the procedures necessary to enable the removal, repair and replacement of the various assemblies and components used in the butane configured burner which are different or additional to those used in the standard burner.

Maintenance other than that detailed in Section 4, (Preventative Maintenance) and Section 6, (Annual / 100 Hour Inspection) should not be carried out unless it is clear that there is a fault or there is a noticeable deterioration in the performance of any part of the equipment functions.

Unless otherwise stated, maintenance specified in this section may only be carried out by Ultramagic or by a maintenance organisation approved by the airworthiness authority in the country of registration.

5.2 Coil Assembly

Removal, repair and replacement of the coil are as described in the Maintenance Manual. Note that the coil used in the butane configured burner is different to the standard burner in that it is provided with larger jets. The jet configuration is identified on the underside of the jet ring. Be sure to quote this information if a replacement coil is required. Butane configured coils are identified "40 x 1.8 x 5" thus.

5.3 Check Valve Assembly

The Check Valve is fitted inside the main valve block machining directly behind the Fuel Inlet Post.

It is vitally important that only parts supplied directly by Ultramagic be fitted when carrying out any maintenance work on the Check Valve. The use of any other part may result in a complete loss of burner function!

The Check Valve fitted for heated fuel is different to that fitted for nitrogen pressurised fuel. It is very important to fit the correct part. Fitting the incorrect part may result in a serious reduction in burner power or excessive burner power. When ordering a replacement Check Valve, consult Ultramagic and state which method of fuel pressurisation is employed.

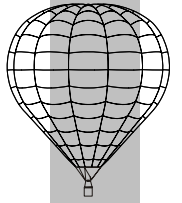

**M
K
2
1
B
U
R
N
E
R
,
B
U
T
A
N
E
F
U
E
L
V
A
R
I
A
N
T**

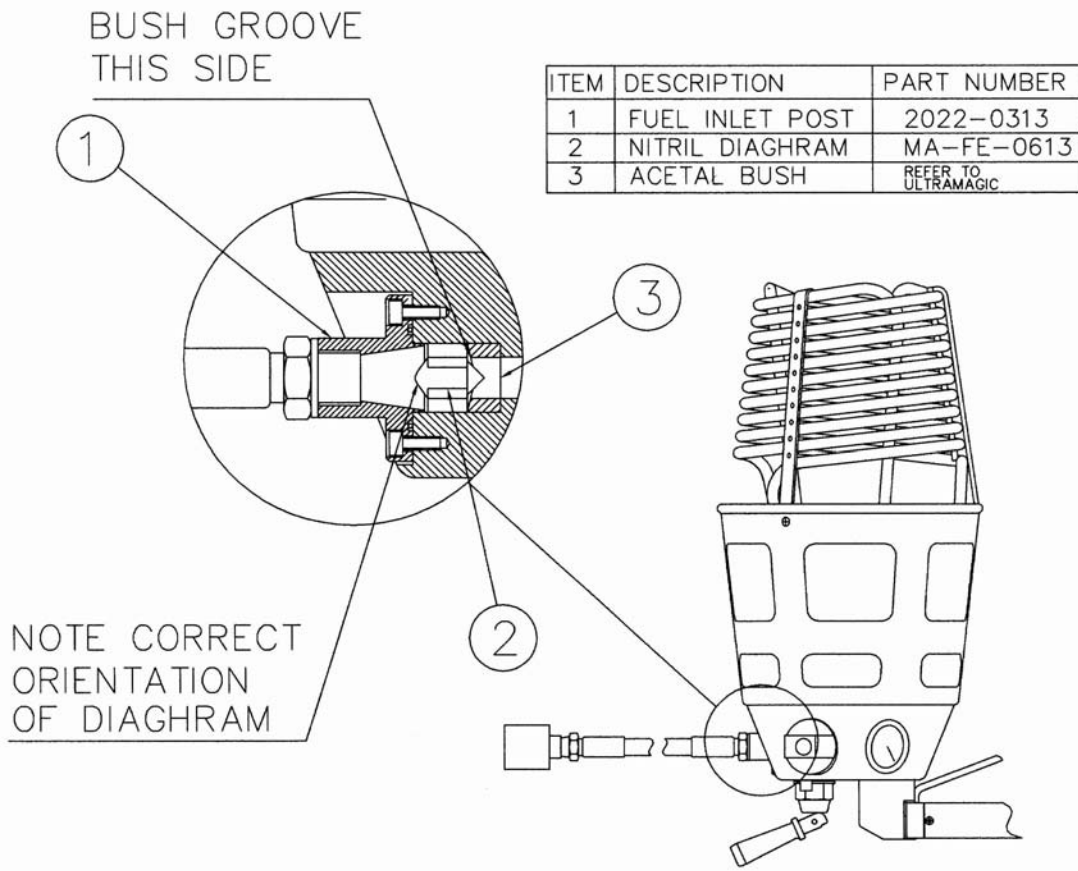
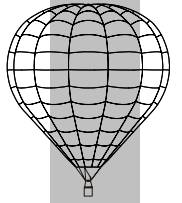

Figure 2. Check Valve Assembly

To remove and replace the Check Valve, refer to Figure 2 and proceed as follows:

- Remove the fuel inlet post as described in the Maintenance Manual.
- Using a length of hooked wire; remove the nitrile diaphragm item 2.
- Using a length of hooked wire; remove the acetal bush item 3.
- Replacement is the reverse procedure of removal. Make sure that the orientation of the acetal bush and nitrile diaphragm is correct.
- Replace the fuel inlet post as described in the Maintenance Manual.

When replacing the Fuel Inlet Post, make sure that the “O” Seal is in good condition and that it is fitted in the groove machined in the rear face. Apply a thin smear of silicon grease to the seal prior to assembly.

Air pressure test as described in the Maintenance Manual.

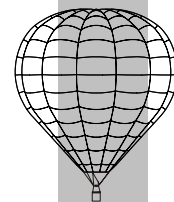

Section 6

6.0 Annual / 100 Hour Inspection Requirements

6.1 General

The burner must be subjected to an inspection by an inspector approved by the national airworthiness authority in the state of registration. The inspection must be carried out every 12 months or 100 hours use, whichever is the sooner.

The inspection requirements detailed below are additional to those already specified in the Maintenance Manual.

6.2 Inspection Requirements

Carry out all functional tests as specified in the Maintenance Manual. In addition, check the following:

- Check the condition of the nitrile diaphragm. Ensure that the fit of the diaphragm inside the valve block bore is good. If the diaphragm is a very loose or very tight fit inside the bore, it must be replaced. Consult Ultramagic.
- Check the orientation of the nitrile diaphragm inside the valve block. Correct if necessary.
- Check the orientation of the Acetal Bush inside the valve block. Correct if necessary.

APPENDIX 1

Butane Burner

Annual / 100 Hour Burner Inspection Checklist

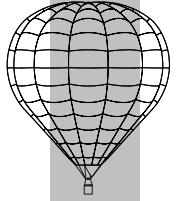

REQUIREMENT	REFERENCE	OKAY	COMMENTS
<u>Nitrile Diaphragm Condition</u>	6.2		
Nitrile Diaphragm Orientation	6.2		
Acetal Bush Orientation	6.2		

**M
K
2
1
B
U
R
N
E
R
,
B
U
T
A
N
E
F
U
E
L
V
A
R
I
A
N
T**