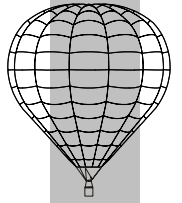

MAINTENANCE MANUAL SUPPLEMENT NUMBER 4 – SOLO / DUO BALLOONS**ULTRAMAGIC SOLO AND DUO****Section 1****1.0 Introduction****1.1 General**

This supplement defines the maintenance and inspection requirements for the Ultramagic SOLO and DUO. Sections 1 to 5 detail the maintenance procedures and the parts used. Section 6 details the annual / 100 hour inspection and test requirements.

1.2 SOLO

The SOLO consists of a main frame, a seat and harness assembly, a special burner and a special 20kg and 30kg fuel cylinder. Note that standard 20kg and 30kg Ultramagic fuel cylinders may be used in conjunction with a fuel manifold.

The burner and special cylinders utilise many common components used in the standard MK-21 burner and the standard fuel cylinders. Only those areas, which are different to the standard burner and cylinders, are therefore described in this supplement.

1.3 DUO

The DUO consists of two SOLO main frames joined together by hinge assemblies. Each frame is fitted with a harness and seat assembly as for the SOLO. A special burner frame supports the burner and is attached to the main frames using two machined suspension blocks and interface tubes. A standard 20kg or 30kg fuel cylinder is attached to each of the main frames in a similar fashion to the SOLO.

All other limitations, instructions and safety information contained in the Maintenance Manual remain applicable.

1.4 Applicability

The information contained in this supplement applies to the Ultramagic SOLO as defined by the following drawing number:

SOLO Assembly:	5001-0000
DUO Assembly	5002-0000

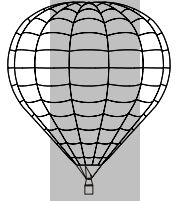

1.5 Replacement Parts and Procedures

See Maintenance Manual.

1.6 Approved Maintenance and Inspection Personnel

See Maintenance Manual.

1.7 Welding and Welders

See Maintenance Manual.

In the event that any repairs are required involving the use of welding, contact Ultramagic for a repair scheme.

1.8 Maintenance Records

See Maintenance Manual

1.9 Technical Support

See Maintenance Manual.

1.10 Safety

The following safety instructions are additional to those already contained in the Maintenance Manual:

- Take care if handling the SOLO when fully assembled and upright, as there is a high risk that the equipment will over-balance. Request the help of an assistant if necessary.
- Ensure that the burner is fully vented of fuel prior to commencement of any work on the burner or fuel hoses.

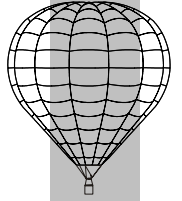

Section 2

2.0 Airworthiness Limitations

2.1 Approval Statement

This supplement provides the maintenance information for the Ultramagic SOLO, as required by BCAR 31 section 31.82, EASA CS 31 HB.82 and FAR 31 section 31.82.

2.2 Mandatory Replacement Time

See Maintenance Manual.

2.3 Inspection Interval

See Maintenance Manual.

Any additional inspection requirements for the SOLO and DUO are defined in Sections 4 and 6 of this Supplement.

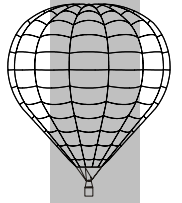

Section 3

3.0 Technical Description

3.1 SOLO

3.1.1 General

The Ultramagic SOLO consists of a stainless steel tubular frame to which are attached a pilot seat and harness assembly, a special burner, a fuel cylinder and a footrest assembly.

The burner is special to the SOLO and is mounted in a frame, which provides single axis burner gimbal. For the purposes of transportation, the burner frame may be detached from the main frame. When assembled to the main frame, the burner frame is secured using four shaft-locking pins. The burner frame is fitted with four suspension lugs, which provide the interface to the envelope flying wires.

During flight, the pilot sits in a special seat, which is provided with an integral harness. The seat and harness assembly is a fabric construction with a plywood base. The harness is attached to the main frame using quick links.

During flight, the fuel cylinder is secured to the rear of the main frame using cylinder straps. The cylinder may be the standard Ultramagic 20kg or 30kg version or the special SOLO 20kg or 30kg cylinder. The special SOLO cylinder is equipped with two liquid feeds providing two fuel feeds to the burner.

When using a standard 20kg or 30kg fuel cylinder, a special fuel manifold is required to provide dual fuel coupling.

The equipment may be seen in Figure 1.

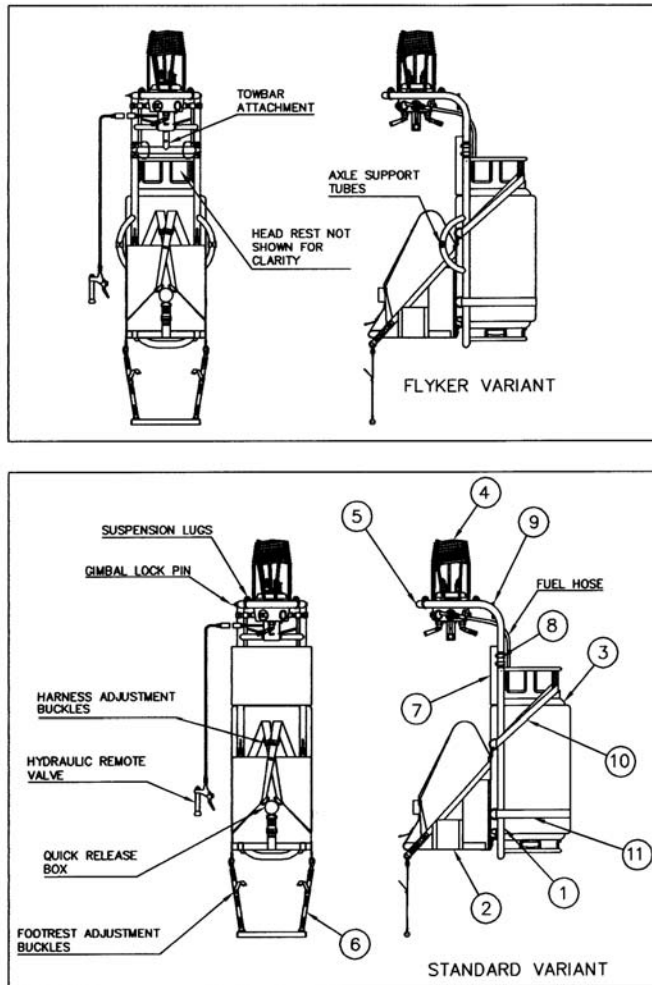
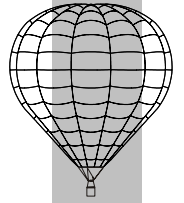

ITEM	DESCRIPTION	PART NUMBER
1	MAIN FRAME ASSY	5001-0200
2	SOLO HARNESS ASSY	5001-0400
3	CYLINDER ASSY	
4	SOLO BURNER ASSY	2025-0000
5	BURNER FRAME ASSY	5001-0300
6	FOOTREST ASSY	5001-0700
7	HEADREST ASSY	5001-0600
8	SHAFT LOCKING PIN	SL-C-0050
9	MIRROR ASSY	5001-0500
10	CYLINDER STRAP (1.1m)	BO-10-0200
11	CYLINDER STRAP (2.1m)	BO-10-0200

FIGURE 1
SOLO CONFIGURATIONS

3.1.2 SOLO Main Frame Assembly

The Main Frame Assembly is a tubular stainless steel welded construction. The frame forms the “backbone” of the equipment and is used to attach all the other major items of equipment.

A small bracket is welded to the bottom of the frame at the rear. This bracket is used to retain the foot ring of the fuel cylinder. On the front of the main frame, a series of “D” lugs are attached. The lugs are used to attach the pilot seat and harness assembly and to act as retainers for the cylinder straps.

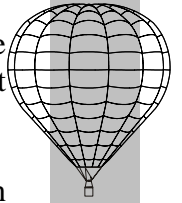

Two machined stainless steel sockets are welded to the top of the frame. The sockets are designed to accept the mating burner frame plugs. Two holes are drilled in each socket into which are inserted the shaft locking pins.

A stainless steel cross-tube links the two vertical tubes of the frame near the top. In standard configuration, the tube acts simply as a stiffener. In the Flyker configuration, an additional tube is welded to the cross tube and acts as the interface to the tow bar.

The main frame used on the DUO is identical to that used on the SOLO with the exception that additional mounting blocks are welded to the frames to allow attachment of the hinge assemblies.

3.1.3 SOLO Harness Assembly

The SOLO Harness Assembly is an integral fabric construction combining a seat and harness. The harness is attached to the main frame “D” lugs using four quick links.

The outer cover of the harness is a sewn Cordura construction reinforced with load tapes. The load tapes form a structural path and are used to transfer the weight of the pilot to the main frame.

The fabric cover is constructed such that the lower section forms a pocket into which a plywood base is inserted. The plywood is covered with a layer of foam both top and bottom to provide additional pilot comfort and to prevent excessive fabric wear, where the plywood is in contact with the cover.

When seated, two shoulder and waist straps and a crotch strap restrain the pilot. A rotary quick-release box secures the straps. The crotch strap is fitted with a red Velcro tab. During flight, the tab is secured to the quick release box wheel preventing inadvertent opening of the box. Harness adjustment is achieved with the use of self locking adjustment buckles.

3.1.4 SOLO Cylinder Assembly

The SOLO may be provided with a special fuel cylinder. The cylinder is a standard Ultramagic 20kg or 30kg cylinder, which has been modified to incorporate a second liquid fuel feed to the burner. The second fuel feed replaces the vapour fuel supply normally found on the standard fuel cylinder. Because the second feed supplies propane in liquid state to the burner, an additional dip tube is fitted to the cylinder fitting.

Note that for the purposes of fuel management, the two dip tubes are of different length. The right hand dip tube provides access to the first eighty five percent of the total fuel contents whilst the left hand dip tube provides access to all of the fuel contents. If for any reason the liquid fuel valves have been removed from the cylinder, it is of great importance to ensure that they are re-assembled to the cylinder in the correct positions, i.e. right-to-right and left-to-left.

Note that the valve handles fitted to the liquid fuel feeds are colour coded. The right-hand handle is blue and the left hand handle is red. The colour coding matches the colours used to identify left and right fuel systems on the burner and it is of vital importance therefore that correct colour coding orientation is maintained.

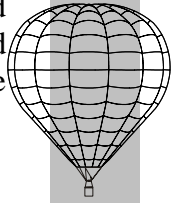

3.1.5 SOLO Burner Assembly

The SOLO Burner Assembly is identical to the Ultramagic Single Burner with the following exceptions:

- No burner can is fitted.
- A smaller, lower power coil is used.
- The method of coil attachment is different.
- The burner mounting arrangement is different.

The burner uses the same valve block to the single burner thus providing two independent burner fuel systems.

Note that the left and right fuel systems are colour coded. All controls associated with the right-hand fuel system are coloured blue. All controls associated with the left-hand fuel system are coloured red. It is of vital importance that the correct colour coding and orientation is maintained.

Since the burner is not fitted with a can, the coil supports extend down to the valve block where they are secured to existing tapped holes in the upper surface of the valve block. Two brackets are fitted to the upper surface of the valve block allowing assembly directly into the SOLO burner frame in such a way as to provide single axis gimbal.

3.1.6 SOLO Burner Frame Assembly

The SOLO burner frame is a welded tubular stainless steel construction. The frame incorporates the following features:

- Suspension lugs used to attach to the envelope flying wires.
- End plugs, which are used to attach the burner frame into the main frame sockets.
- Burner mount pivots allowing single axis burner gimbal.
- Burner gimbal lock pin allowing burner gimbal to be enabled or disabled.
- Mirror mounting bosses.

3.1.7 SOLO Mirror Assembly

The SOLO mirror assembly is a polished stainless steel plate provided with rotation pins at each end. The pins are designed to “snap” into the plastic mounting bushes fitted on the burner frame thus allowing mirror removal for the purposes of transportation, maintenance etc. When mounted, the pins also allow rotation of the mirror to enable individual pilot adjustment of the mirror.

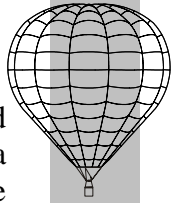

3.1.8 SOLO Fuel Manifold Assembly

When using the special SOLO fuel cylinders, the burner fuel hoses may be connected directly to independent couplings on the cylinder. When a standard cylinder is used, a special fuel manifold is provided allowing both burner hoses to be connected to the single cylinder liquid fuel coupling.

3.1.9 SOLO Footrest Assembly

The footrest assembly consists of load tape straps attached to a stainless steel tube. The straps are provided with adjustment buckles allowing the footrest to be adjusted to accommodate different leg lengths. The straps are terminated with snap hooks allowing rapid attachment of the footrest to the harness.

3.1.10 SOLO Headrest Assembly

A headrest assembly is provided and consists of a fabric cover with a foam insert. Velcro straps attached to the outer cover enable attachment of the headrest to the main frame. The headrest provides a cushion between the pilot's head and the main frame.

3.1.11 Footrest Assembly

A footrest assembly is provided. The assembly consists of a stainless steel tube and two adjustable straps. The assembly is suspended from the harness using two quick release snap hooks.

3.2 DUO

3.2.1 General

The Ultramagic DUO utilises many common components and is essentially a two-seat version of the SOLO.

The DUO consists of two SOLO main frames linked together by two hinge assemblies. The hinges allow the frames to be folded flat for convenient storage and transportation. Each frame is fitted with a seat and harness assembly identical to that used on the SOLO.

The DUO burner is essentially a full power variant of the Ultramagic Single and as such, independent duality of all functions is provided. The burner is mounted in a special frame, which provides the structural interface to the main frames and to the envelope flying wires. The burner frame is linked to the main frames via two special machined suspension blocks and four interface tubes.

Standard fuel cylinders are fitted to the rear of each frame providing independent fuel supplies to each side of the burner. A special foam block is fitted between the two cylinders and provides structural stability when the two cylinders are strapped together.

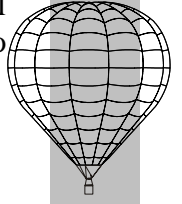

The DUO may be seen in Figure 1.A.

**S
4
S
O
L
O
-
D
U
O
B
A
L
L
O
N
S**

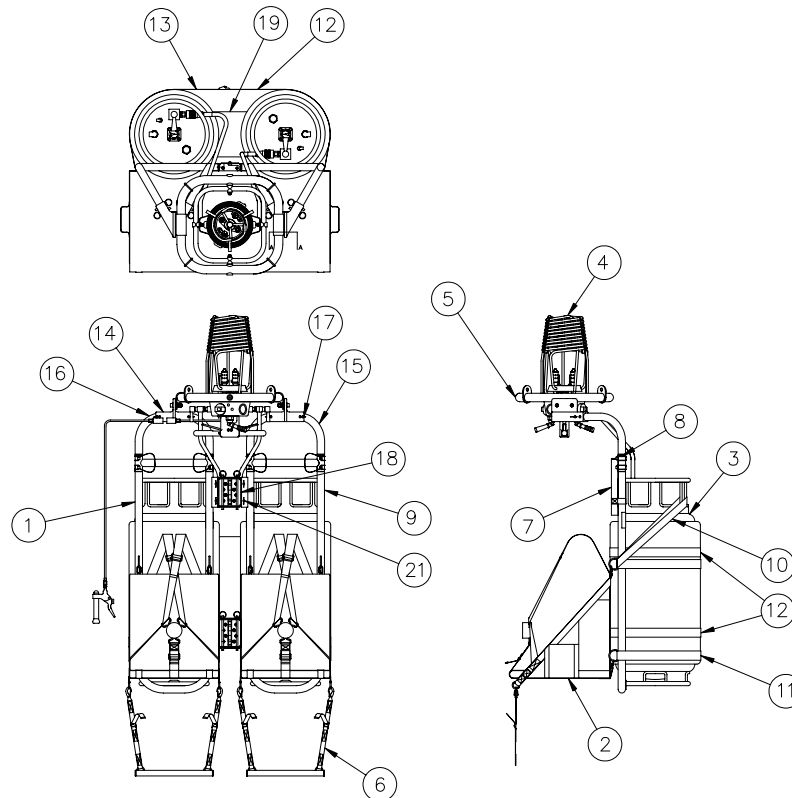
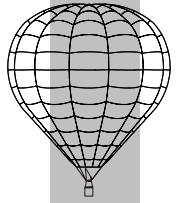

ITEM	DESCRIPTION	PART NUMBER
1	RH MAIN FRAME ASSY	5002-0100
2	SOLO HARNESS ASSY	5001-0400
3	CYLINDER ASSY	
4	DUO BURNER ASSY	2026-0000
5	DUO_BURNER_FRAME ASSY	5002-0300
6	FOOTREST ASSY	5001-0700
7	DUO HEADREST ASSY	5002-0800
8	SHAFT LOCKING PIN	SL-C-0050
9	LH MAIN FRAME ASSY	5002-0200
10	CYLINDER STRAP (1.1m)	BO-10-0200
11	CYLINDER STRAP (2.1m)	BO-10-0200
12	SPECIAL STRAP (BUCKLE)	5002-0016
13	SPECIAL STRAP	5002-0017
14	SUSPENSION BLOCK	5002-0011
15	LH INTERFACE TUBE ASSY	5002-0600
16	RH INTERFACE TUBE ASSY	5002-0500
17	LOCK PIN (50MM)	QU-C-0714
18	HINGE ASSEMBLY	5002-0700
19	FOAM SPACER (30kg)	5002-0400
19	FOAM SPACER (20kg)	5002-0900
20		
21	LOCK PIN (35MM)	QU-C-0715

FIGURE 1.A
DUO CONFIGURATION

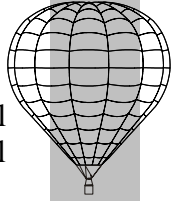

3.2.2 DUO Main Frame Assemblies

The DUO is provided with left and right main frame assemblies. The frames are identical to those used on the SOLO with the exception that they are provided with additional hinge mounting blocks welded to the frame sides.

3.2.3 Harness Assembly

The harness assembly used on the DUO is identical to that used on the SOLO.

3.2.4 Cylinder Assembly

The DUO utilises two standard Ultramagic 20kg or 30kg fuel cylinders.

3.2.5 DUO Burner Assembly

The DUO Burner Assembly is identical to the Ultramagic Single Burner with the following exceptions:

- No burner can is fitted.
- The method of coil attachment is different.
- The burner mounting arrangement is different.
- A hydraulically operated right-hand main valve is fitted as standard

3.2.6 DUO Burner Frame Assembly

The DUO burner frame is a welded tubular stainless steel construction. The frame incorporates the following features:

- Suspension lugs used to attach to the envelope flying wires.
- An inner frame providing two-axis burner gimbal.
- Suspension brackets providing structural interface to the machined suspension blocks.

Machined suspension blocks are bolted to the suspension brackets on the burner frame. The blocks provide socket attachment for the interface tubes. The interface tubes are secured to the blocks using special locking pins. The burner frame is attached to the two main frames by inserting the plugs on the end of the interface tubes in to the sockets on the main frames and securing using the shaft locking pins in a similar fashion to the SOLO.

3.2.7 DUO Suspension Tubes

Four suspension tubes provide the interface between the burner frame and the main frames. The tubes locate inside the machined bores in the suspension blocks and are secured using special locking pins. The other ends of the tubes interface to the main frame assemblies using the shaft locking pins.

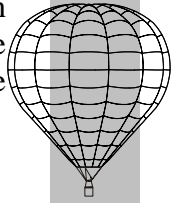

3.2.8 DUO Mirror Assembly

Due to the location of the fuel cylinders and the different method of attaching the burner frame to the main frame, the DUO is provided with two mirror assemblies. The mirrors provide separate images of the fuel contents gauges on the two cylinders. The mirrors are mounted on small handles, which are fitted into sockets on the interface tubes. The mirror heads may be adjusted to provide a clear image of the cylinder contents gauge.

3.2.9 DUO Hinge Assemblies

Two hinge assemblies are fitted between the left and right main frames. The hinges allow the main frames to be folded together for convenient storage and transportation. The hinges are secured to the main frames using special locking pins.

3.2.10 DUO Headrest Assembly

A headrest is provided similar in construction to the SOLO headrest. The headrest differs from the SOLO in that a single headrest is used spanning the combined width of the two main frames.

3.2.11 DUO Footrest Assembly

Two footrest assemblies are provided attached to each harness. The footrests are identical to that used on the SOLO.

3.2.12 DUO Foam Spacer Assembly

The DUO is provided with a special Foam Spacer Assembly. The spacer is fitted between the two cylinders and provides structural rigidity of the two main frames when the special straps are correctly adjusted. The spacer is provided in two sizes to accommodate the different diameters associated with the 20kg and 30kg fuel cylinders.

3.2.13 DUO Special Strap Assemblies

The DUO is provided with two special strap assemblies. The straps are used to pull the two fuel cylinders together thus compressing the foam spacer and providing structural rigidity.

Section 4

4 Preventative Maintenance

4.1 SOLO Preventative Maintenance

4.1.1 General

All preventative maintenance is as described in the Ultramagic Maintenance Manual with the following additions:

4.1.2 SOLO Main Frame Assembly

The Main Frame is a welded assembly and as such preventative maintenance is limited to inspection. Due to the nature of the equipment and the potential for high impact loads during fast landings, it is recommended that the following inspection requirements be made after every 25 hours flying time or after every three months whichever is the sooner.

- Visually inspect all welded joints and check for signs of deterioration and cracking.
- Visually inspect the frame tube for signs of indentation. Indentation is considered significant if the depth of the indentation exceeds 2mm and cannot be contained within a circle of diameter 10mm.
- Visually inspect the four holes where the shaft locking pins are fitted at the joint between the main frame and the burner frame for signs of deterioration, deformation or cracking.
- Visually inspect the “D” lugs fitted on the front of the frame for signs of distortion or cracking.
- Visually inspect the cylinder retaining plate located at the rear bottom of the frame. Check for signs of distortion and cracking.
- Visually inspect the four shaft locking pins used to secure the main frame to the burner frame. Check for correct operation of the spring retaining clips. Check that the pins are not bent. Check for signs of deterioration, cracking and significant surface indentation.

Problems associated with cracking, distortion or indentation must be referred back to Ultramagic for repair instructions.

Repair of the shaft locking pins is by replacement only.

4.1.3 SOLO Harness Assembly

The SOLO Harness is common to the SOLO and DUO and is a sewn fabric assembly. Consequently, preventative maintenance is limited to inspection. Due to the nature of the equipment and the potential for fabric wear during landing, it is recommended that the following inspection requirements be made every 25 hours flying time or after every three months whichever is the sooner.

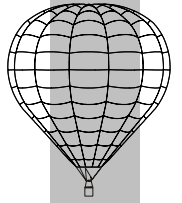

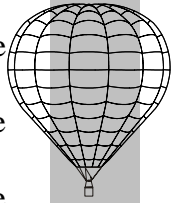

- Visually inspect all load tapes for signs of wear. Pay particular attention to the tapes on the underside of the seat and loops where the quick links are fitted.
- Visually inspect all joints between the load tapes and the fabric. Check that the joints are sound and show no signs of deterioration or excessive loading.
- Visually inspect the sewn joints between the load tapes and the fabric where the load tapes form loops for the quick links. Check for signs of joint separation or “pulled” threads or for any signs of excessive loading.
- Visually inspect the fabric for signs of significant wear. Pay particular attention to the front edge of the seat, especially on the underside.
- Visually inspect all fabric seems. Check that the seems are secure and for signs of separation or excessive loading.
- Inspect the quick links. Check for correct gate operation and that the link is in good condition.
- Insert the tangs into the rotary quick release box. Check that they are secure.
- Check that the harness adjustment buckles function correctly and that they maintain their set positions.
- Check that the two waist strap tangs release correctly when the rotary wheel on the quick release box is operated and that the tang attached to the crotch strap remains secure inside the box.

Problems associated with the load tapes or the joints of the load tape to the fabric must be referred back to Ultramagic for repair instructions.

Problems associated with fabric wear must be referred back to Ultramagic for repair instructions.

Repair of the rotary quick release box is by replacement only. Under no circumstances may the rotary quick release box be disassembled.

Quick link repair is by replacement only.

4.1.4 Cylinder Assembly

The following requirements are additional to the cylinder instructions contained in the Ultramagic Maintenance Manual.

Cylinder preventative maintenance is limited to visual inspection. Due to the nature of the equipment and the potential for high impact loads during landing, it is recommended that the following inspection requirements be made every 25 hours flight time or every three months whichever is the sooner or if the pilot judges that the equipment has been subject to a heavy or fast landing.

- Visually inspect the lower support ring for signs of excessive distortion.
- Check that the lower support ring correctly locates over the cylinder retaining plate on the main frame.
- Visually inspect the welded joints between the lower support ring and the cylinder body for signs of deterioration and cracking.

- Remove the cylinder protective jacket and inspect the cylinder body for signs of indentation. Pay particular attention to the area around the joints between the lower support ring and the cylinder body.

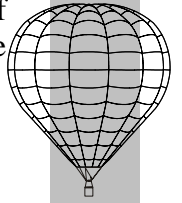

Damaged cylinders must be returned to Ultramagic.

4.1.5 SOLO Burner Assembly

The following requirements are additional to the burner instructions contained in the Ultramagic Maintenance Manual.

Every 25 hours flight time or every three months (whichever is the sooner) check the following:

- Check that the three screws securing the coil support legs to the valve block are secure and tight.
- Check that the two bolts inserted through the burner frame securing the burner to the frame are secure and tight.
- Check for the correct function of the hydraulic valve (if fitted) and that there are no hydraulic fluid leaks.
- Check for the correct function of the two Isolation Valves.

4.1.6 SOLO Burner Frame Assembly

The SOLO Burner Frame is a welded assembly and as such preventative maintenance is limited to inspection. Due to the nature of the equipment and the potential for high impact loads during fast landings, it is recommended that the following inspection requirements be made after every 25 hours flying time or after every three months whichever is the sooner.

- Visually inspect all welded joints and check for signs of deterioration and cracking.
- Visually inspect the frame tube for signs of indentation. Since the burner frame is structural, no indentation is permitted.
- Visually inspect the four holes where the shaft locking pins are fitted at the joint between the main frame and the burner frame for signs of deterioration, deformation or cracking.
- Visually inspect the suspension lugs for signs of distortion or cracking.
- Check the condition of the pins securing the burner frame to the Suspension Blocks and that the pin locking mechanism is fully functional.

Problems associated with cracking, distortion or indentation must be referred back to Ultramagic for repair instructions.

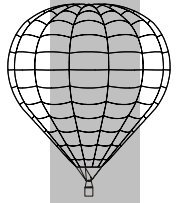

4.1.7 SOLO Mirror Assembly

See Annual / 100 hour Inspection requirements.

4.1.8 SOLO Fuel Manifold Assembly

See Annual / 100 hour Inspection requirements.

4.1.9 SOLO Headrest Assembly

See Annual / 100 hour Inspection requirements.

4.1.10 SOLO Footrest Assembly

See Annual / 100 hour Inspection requirements.

4.2 DUO Preventative Maintenance

4.2.1 General

All preventative maintenance is as described in the Ultramagic Maintenance Manual with the following additions:

4.2.2 DUO Main Frame Assemblies

See SOLO main frame preventative maintenance requirements section 4.1.2.

4.2.3 DUO Harness Assemblies

See SOLO harness preventative maintenance requirements section 4.1.3.

4.2.4 DUO Fuel Cylinders

See SOLO cylinder preventative maintenance requirements section 4.1.4.

4.2.5 DUO Burner Assembly

The following requirements are additional to the burner instructions contained in the Ultramagic Maintenance Manual.

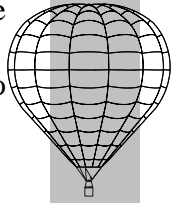

- Check that the three screws securing the coil support legs to the valve block are secure and tight.
- Check for the correct function of the hydraulic valve and that there are no hydraulic fluid leaks.
- Check that the fixings securing the burner to the inner frame are secure and tight.
- Check for the correct function of the two Isolation Valves.

4.2.6 DUO Burner Frame Assembly

The DUO Burner Frame is a welded assembly and as such preventative maintenance is limited to inspection. Due to the nature of the equipment and the potential for high impact loads during fast landings, it is recommended that the following inspection requirements be made after every 25 hours flying time or after every three months whichever is the sooner.

- Visually inspect all welded joints and check for signs of deterioration and cracking.
- Visually inspect the frame tube for signs of indentation. Since the burner frame is structural, no indentation is permitted.
- Visually inspect the suspension lugs for signs of distortion or cracking.
- Check that the four bolts securing the burner frame to the Suspension Blocks are secure and tight.
- Check the Suspension Blocks for any signs of deterioration and cracking.
- Check that the two bolts securing the inner frame to the outer frame are secure and tight.

Problems associated with cracking, distortion or indentation must be referred back to Ultramagic for repair instructions. Damaged pins must be replaced.

4.2.7 DUO Interface Tubes

The interface tubes are a welded tubular construction and as such, preventative maintenance is limited to inspection. Due to the nature of the equipment and the potential for high impact loads during fast landings, it is recommended that the following inspection requirements be made after every 25 hours flying time or after every three months whichever is the sooner.

- Visually inspect all welded joints for signs of deterioration and cracking.
- Visually inspect the tubes for signs of indentation or cracking. Since the tubes are structural, no indentation or cracking is permitted.
- Check the condition of the pins securing the Interface Tubes to the Suspension Blocks and that the pin locking mechanism is fully functional.
- Check the condition of the pins securing the tubes to the suspension blocks. Ensure correct function of the pin locking mechanism.
- Check the condition of the holes where the pins are used to secure the tubes to the main frame for signs of deterioration, deformation or cracking.
- Check the condition of the holes where the pins secure the tubes to the suspension blocks for signs of deterioration, deformation or cracking.

Problems associated with cracking, deformation, distortion or indentation must be referred back to Ultramagic for repair instructions.

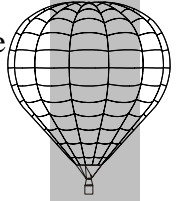

4.2.8 DUO Mirror Assemblies

See Annual / 100 hour Inspection requirements.

4.2.9 DUO Hinge Assemblies

There are two Hinge Assemblies linking the left and right Main Frames. Due to the nature of the equipment and the potential for high impact loads during fast landings, it is recommended that the following inspection requirements be made after every 25 hours flying time or after every three months whichever is the sooner.

- Check that all fixings securing the hinge to the two brackets are secure and tight.
- Check the brackets for signs of excessive distortion and cracking.
- Check the condition of the pins securing the brackets to the main frames for signs of deterioration and distortion. Check that the pin locking mechanism functions correctly.
- Check the condition of the long pins used to prevent hinge rotation. Check for signs of deterioration and distortion and that the locking mechanism functions correctly.

Damaged pins must be replaced.

4.2.10 DUO Headrest Assembly

See Annual / 100 hour Inspection requirements.

4.2.11 DUO Footrest Assemblies

See Annual / 100 hour Inspection requirements.

4.2.12 DUO Foam Spacer Assembly

See Annual / 100 hour Inspection requirements.

4.2.13 Special Strap Assembly (DUO Only)

See Annual / 100 hour inspection requirements.

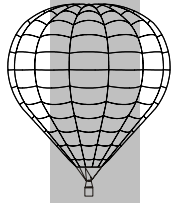

Section 5

5 Repair and Maintenance

5.1 General

This section describes the procedures necessary to enable the removal, repair and replacement of the various assemblies used within the SOLO and DUO. When considering the burner and fuel cylinders, only those areas, which are different or additional to those already covered in the Ultramagic Maintenance Manual, are discussed.

Maintenance other than that detailed in the Section 4, (Preventative Maintenance) and Section 6, (Annual / 100 Hour Inspection) should not be carried out unless it is clear that there is a fault or there is a noticeable deterioration in performance.

Unless otherwise stated, maintenance specified in this section may only be carried out by Ultramagic or by a maintenance organisation approved by the airworthiness authority in the country of registration.

Whenever a part or assembly whose removal breaks the pressure integrity of any part of the fuel system is removed and replaced, the re-assembled joint(s) must be subjected to a pressure test. Connect the equipment to a 7Bar (100-psi) compressed air supply and test the joint using soapy water. If bubbles are detected during the test, there is a leak, which must be rectified before further use.

5.2 SOLO

5.2.1 SOLO Main Frame Removal

To remove the main frame, refer to Figures 1 and 2 and proceed as follows:

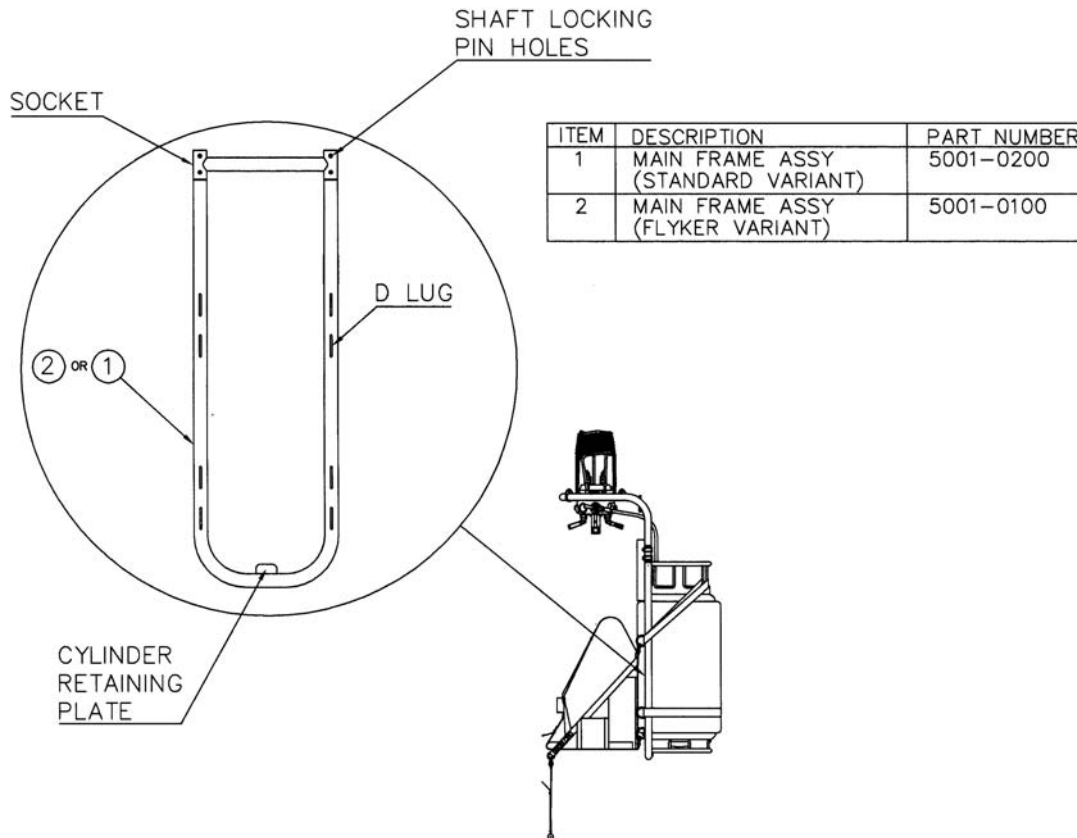
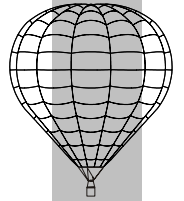

FIGURE 2
SOLO MAIN FRAME ASSEMBLY

- Turn off the cylinder fuel valves and make sure that the burner and fuel hoses are fully vented of fuel.
- Disconnect the fuel hoses from the cylinder.
- Release and remove the four, shaft locking pins item (8, figure 1).
- Remove the burner and burner frame assembly from the main frame. Place the burner and burner frame assembly carefully on a non-abrasive surface.
- Release the Velcro straps securing the headrest to the main frame. Remove the headrest from the main frame.
- Undo and remove the four quick links securing the harness assembly to the main frame. Remove the harness assembly and footrest assembly as one.
- Undo and remove the lower tank strap.
- Undo and remove the upper tank straps.
- Remove the cylinder from the main frame.

Re-assembly is generally the reverse procedure to disassembly. Note that when re-assembling; take care to ensure that the four quick links securing the harness are secure and that the gates are closed and tight. In addition, make sure that all four shaft-locking pins are fitted and that the spring retaining clips are closed.

Maintenance procedures are limited to inspection as described in section 4.1.2. Note that any frame damage must be referred to Ultramagic for repair instructions.

5.2.2 SOLO Harness Assembly Removal

To remove and dismantle the harness assembly, refer to figures 1 and 3 and proceed as follows: Note that the SOLO and DUO utilise the same harness.

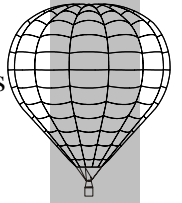

S
4
S
O
L
O
-
D
U
O
B
A
L
L
O
N
S

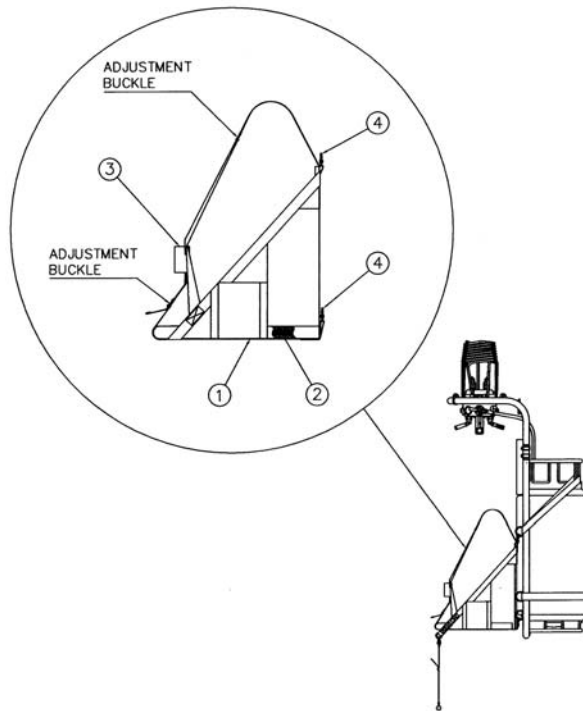

ITEM	DESCRIPTION	PART NUMBER
1	SEAT COVER ASSY	5001-0401
2	SEAT BASE ASSY	5001-0402
3	QUICK RELEASE BOX ASSY	5001-0403
4	4mm 1400kg QUICK LINK	EM-01-0120

FIGURE 3
HARNESS ASSEMBLY

- Undo the four quick links securing the harness assembly to the main frame.
- Detach the quick links from the main frame and lift the harness away from the main frame.
- Separate the Velcro at the rear of the seat. Pull out the seat base assembly from within the fabric pocket.

The seat base assembly consists of a plywood base, enclosed within a foam sheet. The foam is folded around the front of the plywood and provides a degree of protection to the front edge of the plywood and prevents wear between the plywood and the harness fabric. Do not remove the foam unless it is considered that the plywood base is damaged. If damage is suspected, remove the foam using a sharp knife to cut the tape. Visually inspect the plywood base. Repair of the base is by replacement only.

5.2.3 SOLO Cylinder Assembly Disassembly

The following instructions are additional to the cylinder instructions already contained in the Ultramagic Maintenance Manual and refer only to the special SOLO cylinders. All maintenance requirements for the standard fuel cylinders are specified in the Ultramagic Maintenance Manual.

The SOLO cylinder is recognisable by an additional liquid take off valve. The valve corresponds to the right hand fuel supply and as such is fitted with a blue handle.

To change the valve handle and to remove the valve, refer to figure 4 and proceed as follows:

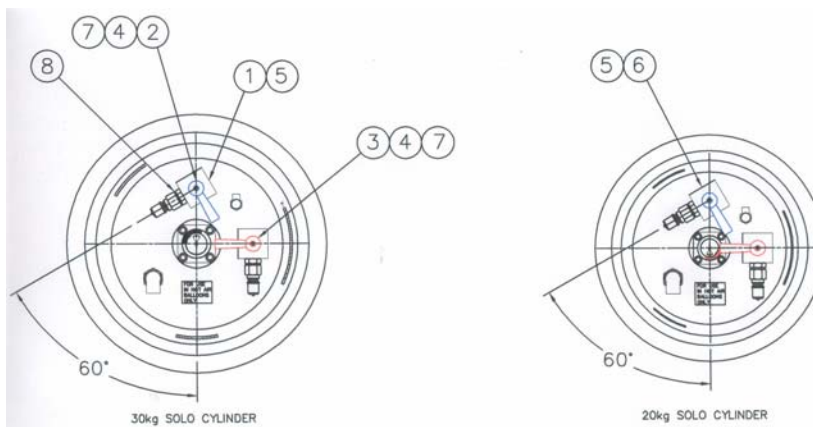

ITEM	DESCRIPTION	PART NUMBER
1	30kg CYLINDER LIQUID TAKE OFF VALVE ASSY	4003-F001
2	VALVE HANDLE (SHORT, BLUE)	BO-FP-0140
3	VALVE HANDLE (SHORT, RED)	CR-C-0430
4	M4 X 20 ST STL C.SINK HEX DRIVE SCREW	CR-O3-0030
5	PTFE TAPE	BO-FP-0130
6	20kg CYLINDER LIQUID TAKE OFF VALVE ASSY	4002-F001
7	LOCTITE 222	
8	3/8" BSP NITRILE BONDED WASHER	MA-FE-0600

FIGURE 4
SOLO FUEL CYLINDERS

- The valve handles items 2 and 3 may be removed without the necessity to empty the cylinder of fuel. Using a 2.5mm Allen key, undo and remove the countersink screw item 4 from the top of the valve handle. Withdraw the handle.
- When replacing the handle, apply Loctite 222 to the screw thread.

Prior to removing the valve, make sure that the cylinder is completely vented of fuel as described in the Ultramagic Maintenance Manual.

To remove the valve from the 20kg SOLO cylinder, it will be necessary to remove the self-sealing coupling fitted to the valve first.

- Using an open-ended spanner, undo and remove the self-sealing coupling from the valve body.
- Carefully withdraw the bonded washer from the valve body.

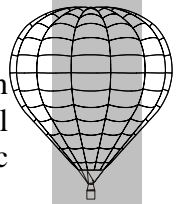

Depending upon the exact location of the cylinder handle support, it may be possible to remove the valve from the 30kg SOLO cylinder without the need to remove the self-sealing coupling first. If this is not the case, remove the coupling as described above.

- Using a 35mm open-ended spanner, undo and withdraw the valve from the cylinder.

Note that the right hand liquid take off valve is different to the left hand valve in that the dip tube is welded directly to the bottom of the valve body. It is very important to ensure that the dip tube length is correct for the 20kg and 30kg cylinders. Check the lengths are in accordance with figure 5 prior to fitting in the cylinder.

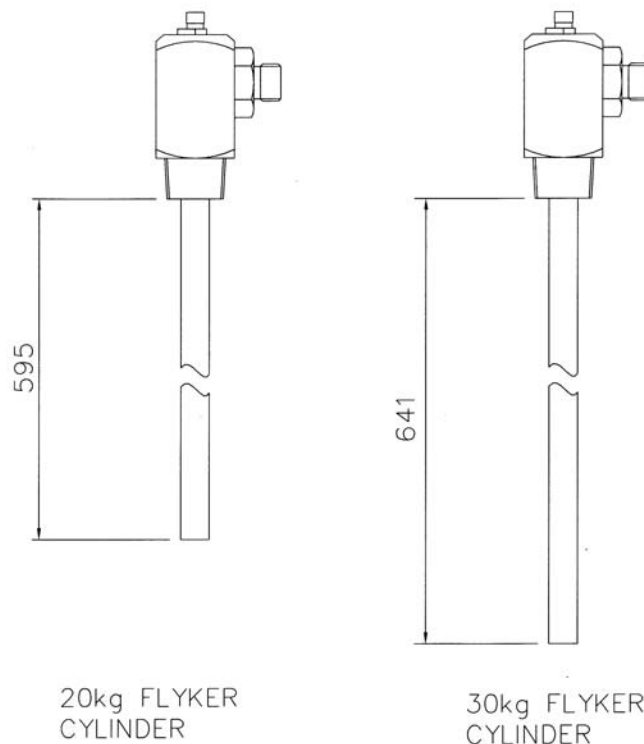
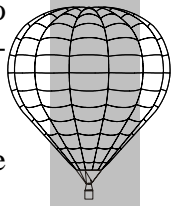
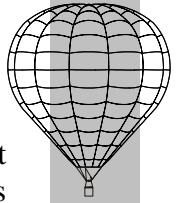

FIGURE 5
VALVE DIP TUBE LENGTHS

Replacement is generally the reverse procedure of removal. Prior to replacing the valve body, remove the old PTFE tape from the thread and replace with new PTFE tape. For tightening instructions, refer to the Ultramagic Maintenance Manual. Ensure that the valve orientation is in accordance with that shown in figure 4.

The procedure to remove and replace the fuel contents gauge is as described in the Ultramagic Maintenance Manual. However, it is important to make sure that when replacing the gauge, the gauge float is positioned such that it does not foul on either of the two liquid feed dip tubes.





5.2.4 SOLO Burner Assembly

5.2.4.1 SOLO Burner Colour Coding

The SOLO and DUO burners are provided with colour coded controls and hoses to assist with the correct fuel management of the equipment. Whenever maintenance work is carried out on the burner, ensure that correct colour coding is maintained. Controls and hoses coloured red are dedicated to the burner left hand fuel circuit. Controls and hoses coloured blue are dedicated to the burner right hand fuel circuit. If in doubt, contact Ultramagic.

5.2.4.2 SOLO Burner Assembly

The SOLO burner is based upon the Ultramagic Single burner and uses many common components. The major differences lie in the design of the coil, the method of burner mounting, the fuel hoses, additional isolation valves and the removal of the burner can. The following instructions therefore only address those areas where the burner is different to the Single burner. For single burner maintenance requirements, refer to the Ultramagic Maintenance Manual.

The burner may be seen in figure 6.

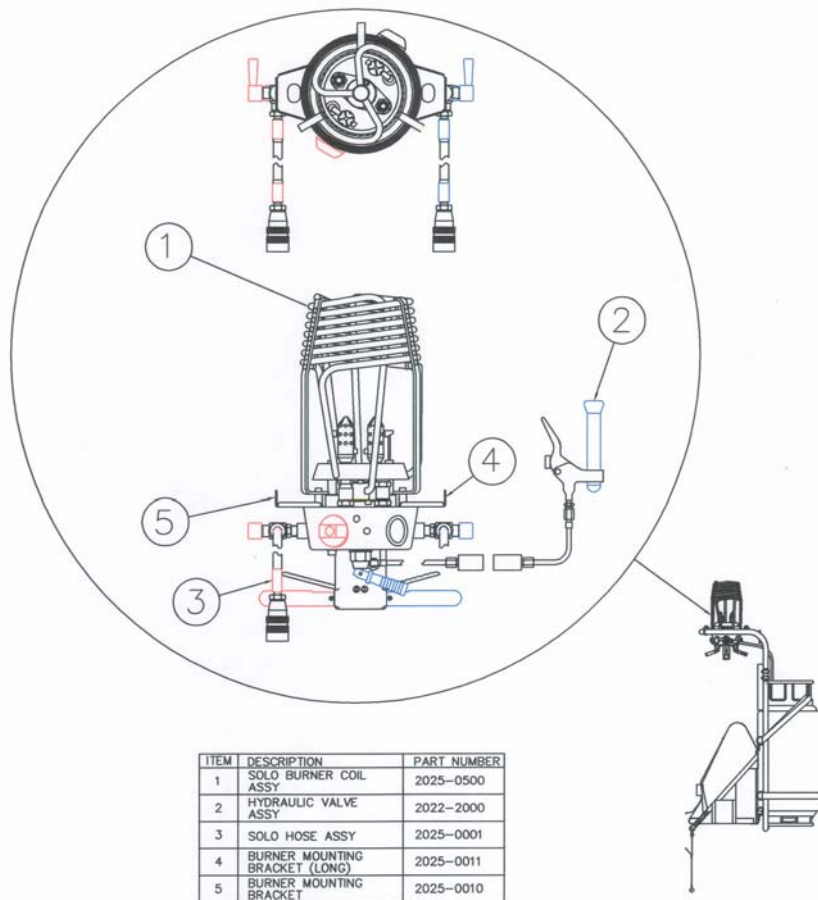

FIGURE 6
SOLO BURNER ASSEMBLY

5.2.4.3 Removal of SOLO Burner From Burner Frame

To remove the burner from the burner frame, refer to figure 7 and proceed as follows:

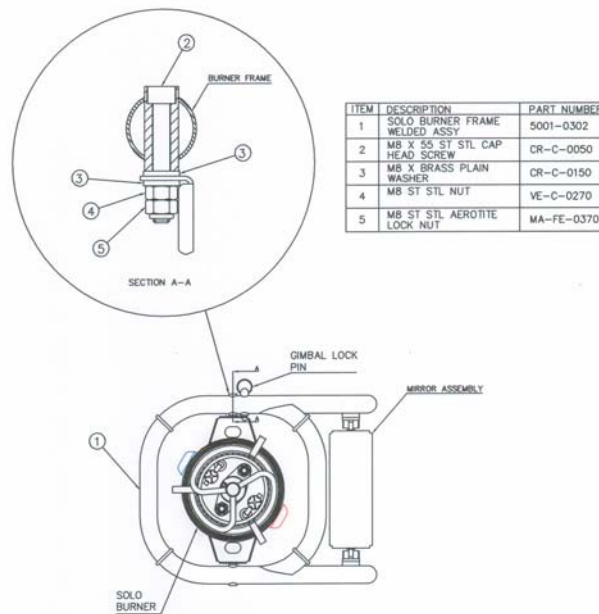
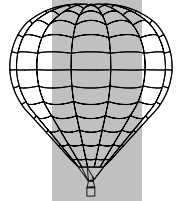

FIGURE 7
SOLO BURNER MOUNTING

- Before commencing work, ensure that the burner is completely vented of fuel and that the fuel hoses are detached from the fuel cylinder.
- Ensure that the burner is supported before removing the mountings. To facilitate this, it is recommended that the burner and burner frame assembly be removed from the main frame.
- Withdraw the Gimbal Lock Pin and rotate the pin so that it remains in the withdrawn position.
- Using a 6mm Allen key and a 13mm open-ended spanner, undo and remove the right hand lock nut and the plain nut items 5 and 4.
- Undo and remove the left hand lock nut and plain nut in a similar fashion.
- Withdraw the bolts item 2 and the brass washers item 3.
- Withdraw the burner from the burner frame.

Re-assembly is generally the reverse procedure of removal. Make sure that the brass washers are fitted in the correct positions.

Note that when replacing the burner, it is very important to ensure that the correct colour coding orientation is maintained. The burner must be orientated such that the red burner handle is on the left hand side. Left is defined as the side to the pilot's left when seated in the harness.

5.2.4.4 SOLO Burner Coil Assembly Removal

To prevent the risk of damage to the burner mounting brackets, it is recommended that the burner be removed from the burner frame before removing the coil. Refer to section 5.2.4.3.

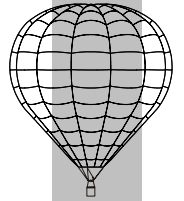

To remove the coil assembly, refer to figure 8 and proceed as follows:

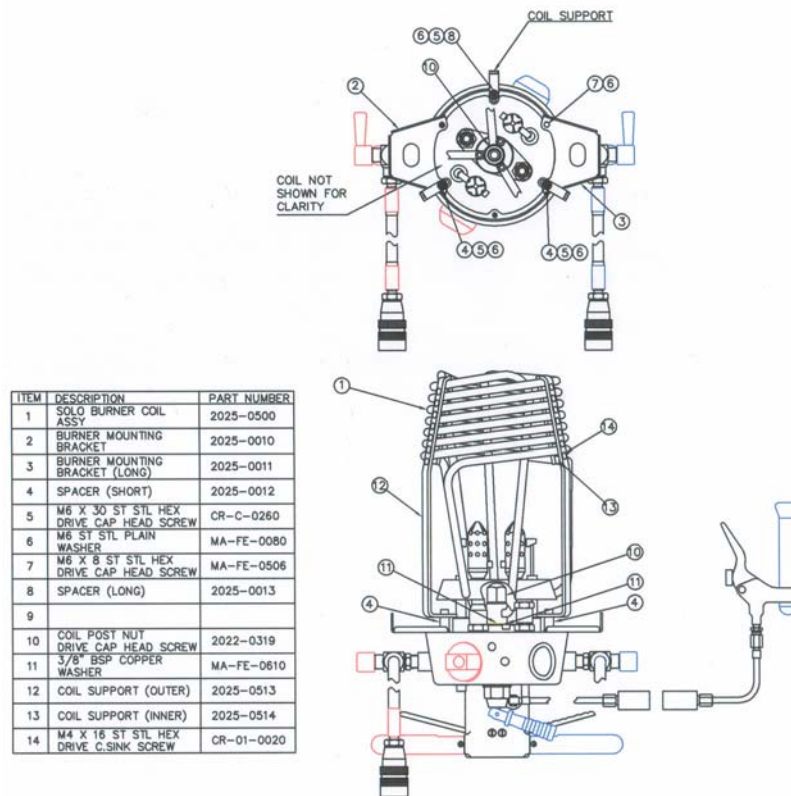

FIGURE 8
SOLO COIL AND BURNER MOUNTING BRACKETS

- Ensure that the burner is completely vented of fuel.
- Using a 24mm socket and extension bar, undo and remove the coil post nut item 10.
- Remove the upper copper washer item 11.
- Using a 5mm Allen key, undo and remove the three cap head screws and washers items 5 and 6 securing the coil supports to the valve block. Remove the spacers items 4 and 8.
- Withdraw the coil from the valve block.

Further coil maintenance is as described in the Ultramagic Maintenance Manual.

Replacement of the coil is generally the reverse procedure of removal. Fit new copper washers item 11. Ensure that the two short spacers are fitted under the coil supports where the supports are positioned above the burner support brackets.

Pressure test the joints between the coil and the coil post using soapy water.

5.2.4.5 SOLO Burner Coil Support Removal

To remove the coil supports, refer to figure 8 and proceed as follows:

- Remove the coil assembly as described in section 5.2.4.4.
- Using a 3mm AF Allen key, undo and remove the seven, countersink screws item 14 securing the outer coil support item 12 to the inner coil support item 13.
- Remove the outer and inner coil supports.

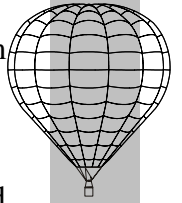

Replacement is generally the reverse procedure of removal. When replacing the inner and outer coil supports, it will be necessary to position them correctly on the coil. Use the mounting hole in the valve block to align the supports. Ensure that all fixing screws are secure and tight.

5.2.4.6 SOLO Burner Mounting Bracket Removal

To remove the burner mounting brackets, refer to figure 8 and proceed as follows:

- Remove the burner from the burner frame as described in section 5.2.4.3 above.
- Using a 5mm Allen key undo and remove the two cap head screws and washers items 5, and 6 securing the coil supports over the burner mounting brackets to the valve block.
- Remove the spacers' item 4.
- Using a 5mm Allen key, undo and remove the two cap head screws and washers items 7 and 6 securing the burner mounting brackets to the valve block.
- Withdraw the burner mounting brackets items 2 and 3.

Replacement is generally the reverse procedure of removal. Ensure that the burner mounting brackets are fitted in the correct positions. The “Long” bracket item 3 must be positioned above the blue burner handle to enable the correct function of the gimbal lock pin fitted in the burner frame.

5.2.4.7 SOLO Hydraulic Valve Removal (Optional Fit)

Maintenance of the hydraulic valve is covered in the Ultramagic Maintenance Manual. The following instructions refer only to the removal of the valve from the burner.

To remove the valve from the burner, refer to figure 9 and proceed as follows:

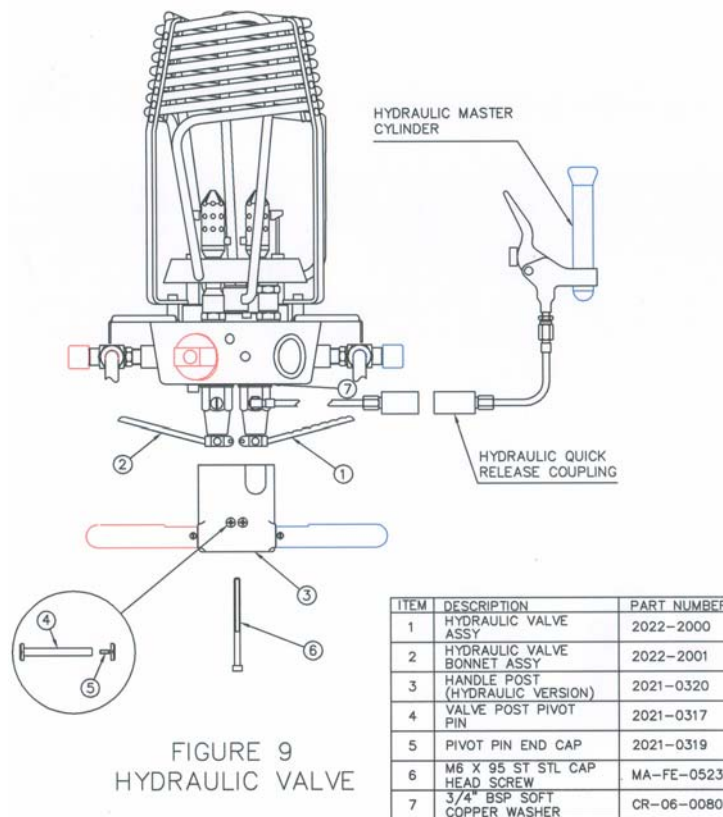
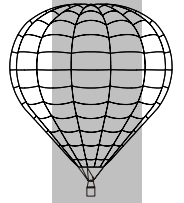

FIGURE 9
HYDRAULIC VALVE

- Ensure that the burner is completely vented of fuel.
- Using two flat bladed screwdrivers, undo and remove the two Valve Post Pivot Pins item 4 and the two Pivot Pin End Caps item 5.
- Using a 5mm Allen key, undo and remove the two cap head screws item 6.
- Withdraw the Handle Post item 3.
- In order to remove the Hydraulic Valve Assembly without removing the hydraulic fitting in the side of the valve bonnet, it will be necessary to remove the left hand valve first. Using a 28mm open-ended spanner, undo and remove the left hand valve item 2.
- In order to protect the hydraulic hose, disconnect the hydraulic master cylinder from the valve by undoing the hydraulic quick release coupling.
- Using a 28mm open-ended spanner, undo and remove the hydraulic valve from the valve block.

Further valve maintenance is as described in the Ultramagic Maintenance Manual.

Replacement is generally the reverse procedure of removal. When replacing the valve, ensure that the hydraulic fitting in the side of the valve bonnet is positioned such that the fitting may pass through the aperture in the side of the valve post. To achieve this, it may be necessary to select a 3/4" BSP soft copper washer of different thickness. These may be obtained from Ultramagic.

Prior to replacing the handle post item 3, check for leaks by attaching a 7 bar (100 psi) air supply to each fuel hose. Check the joints between the valve bonnets and the valve block and the positions where the valve stems exit the valve bonnets using soapy water. Check also that the valve function is correct by operating the valve and making sure that the airflow is enabled and disabled from the coil jet ring.

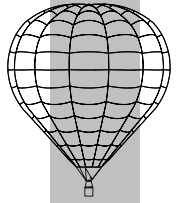

Prior to replacing the cap head screws item 6, apply Loctite 222 to the screw threads.

5.2.4.8 SOLO Burner Fuel Hose Removal

To remove the burner fuel hoses, refer to figure 10 and proceed as follows:

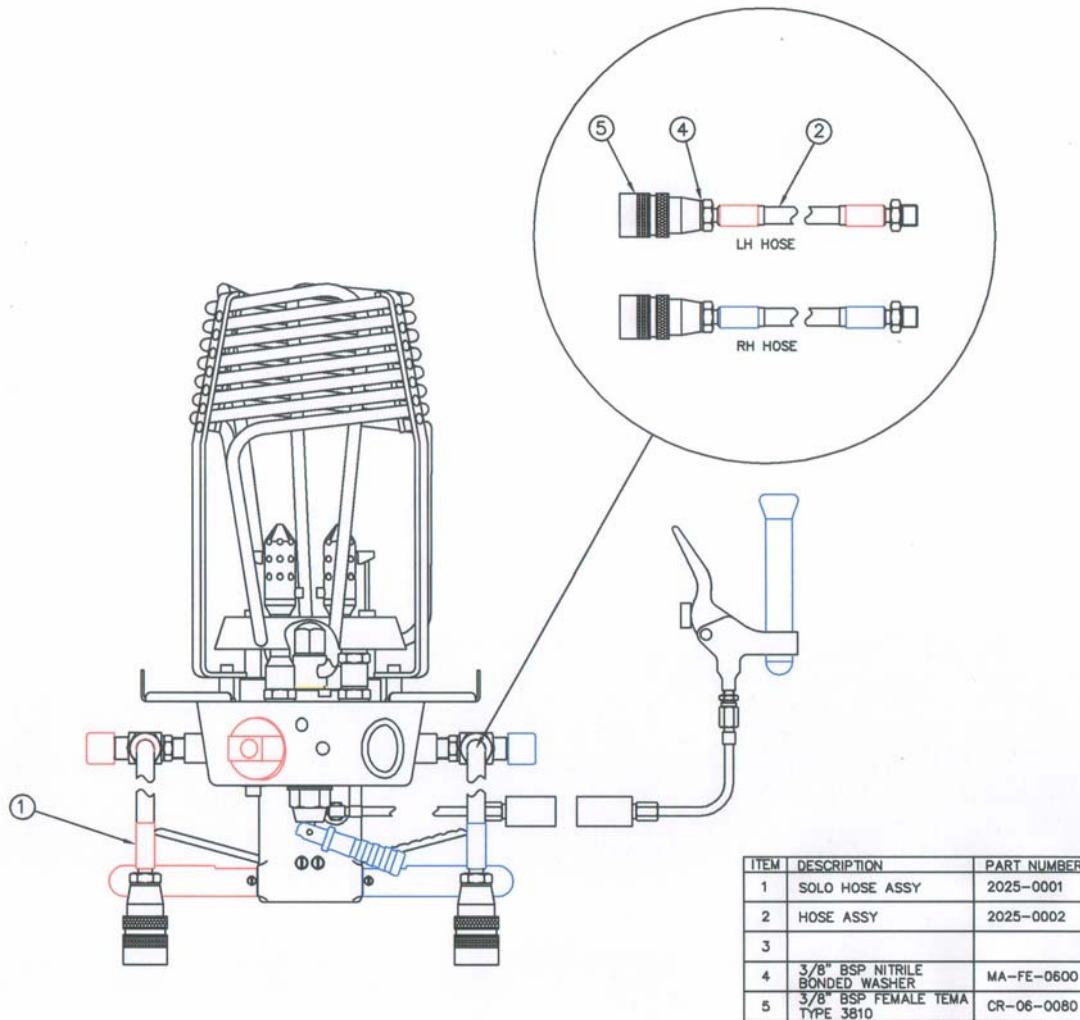
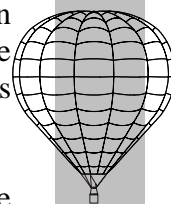

FIGURE 10
BURNER FUEL HOSES

- Ensure that the burner is completely vented of fuel.
- Using an open-ended spanner undo and remove the hose from the Isolation Valve inlet.
- Remove the 3/8" BSP bonded washer from the hose thread.
- The burner hose may be further dismantled using open ended spanners.

Note that the fuel hose diameter used on the SOLO is smaller than the hose used on all other MK21 burners.



Re-assembly is generally the reverse procedure of removal. If the hose has been dismantled, ensure that the 3/8" BSP bonded washer is fitted between the hose and the Tema coupling. When replacing the hose, ensure that the 3/8" BSP bonded washer is fitted between the hose and the valve body.

After re-assembly, pressure test the hose by connecting a 7 bar (100 psi) air supply to the hose coupling. Check all hose joints and the joint between the hose and the isolation valve block using soapy water.

Note that the hoses are colour coded to assist in the correct fuel management of the equipment (see flight manual supplement). It is very important to ensure that the left (red) fuel hose is connected to the left hand burner fuel circuit and that the right hand (blue) fuel hose is connected to the right hand burner fuel circuit. Left is defined as the side to the pilot's left when seated in the harness. Similarly, right is defined as the side to the pilot's right when seated in the harness.

5.2.5 SOLO Burner Frame

5.2.5.1 SOLO Gimbal Lock Pin Removal

To remove the gimbal lock pin assembly, refer to figure 11 and proceed as follows:

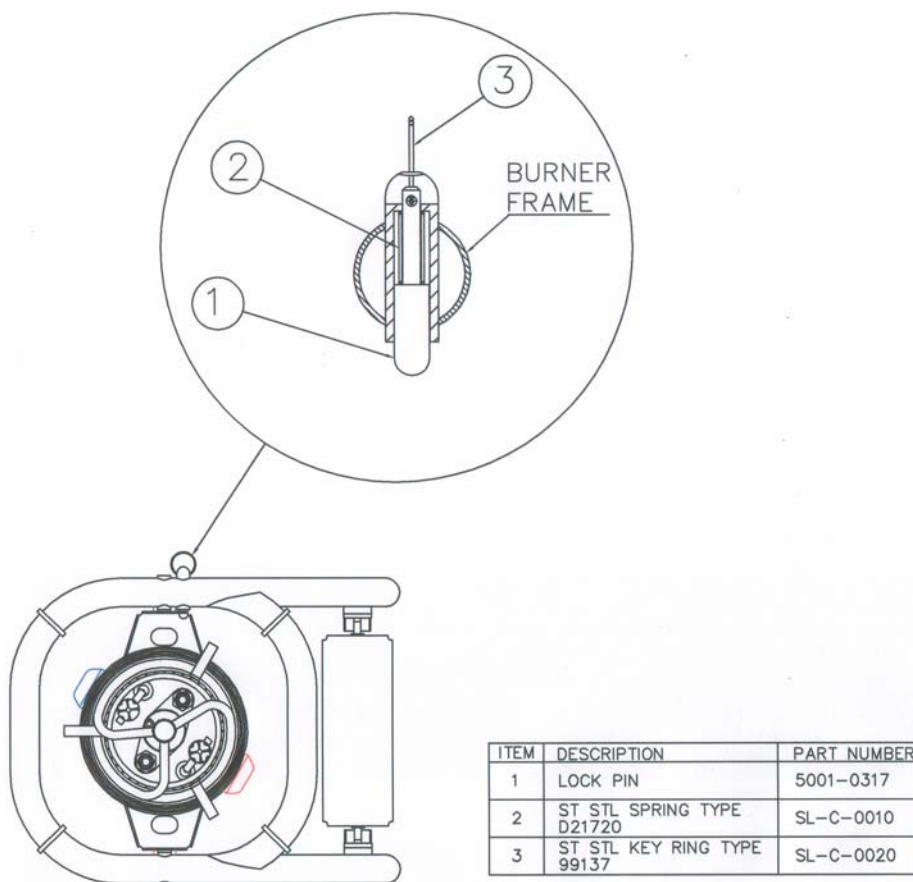
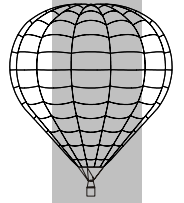

FIGURE 11
LOCK PIN ASSEMBLY



- Remove the key ring item 3 from the lock pin.
- Withdraw the lock pin and spring items 1 and 2 from within the boss.

Replacing the lock pin assembly is generally the reverse procedure of removal.

5.2.5.2 SOLO Mirror Assembly Removal

To remove the mirror assembly, refer to figure 12 and proceed as follows:

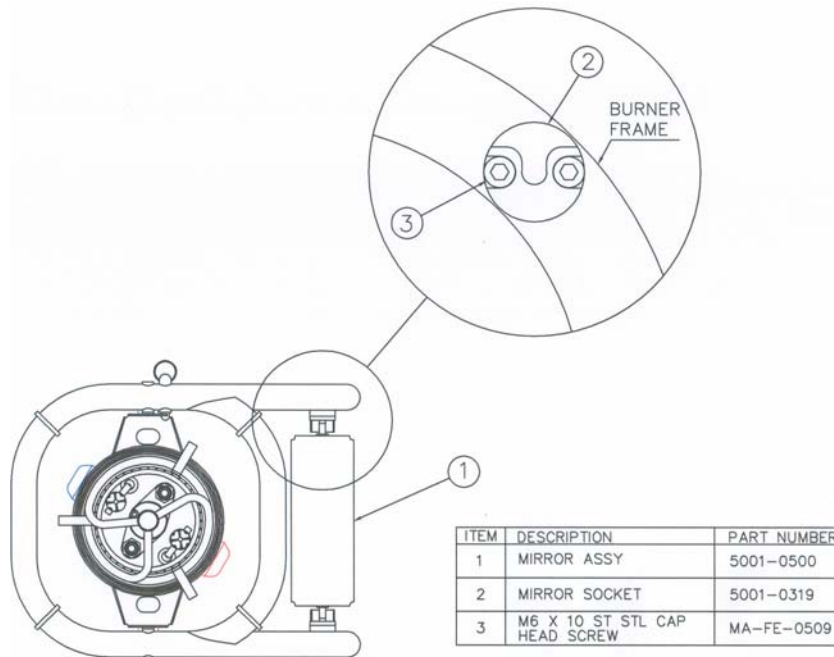

FIGURE 12
MIRROR ASSEMBLY

- Carefully pull the mirror pivot pins from the two mirror sockets and withdraw the mirror.
- The mirror sockets may also be removed. Using a 5mm Allen key, undo and remove the two cap head screws item 3. The socket may now be removed.

Re-assembly is generally the reverse procedure of removal. Use Loctite 222 on the screw threads prior to replacing.

5.2.5.3 SOLO Burner Frame Removal

To remove the burner frame, proceed as follows:

- Remove the burner as described in section 5.2.4.3
- Remove the gimbal lock pin as described in section 5.2.5.1.
- Remove the mirror as described in section 5.2.5.2.

Re-assembly is generally the reverse procedure of removal.

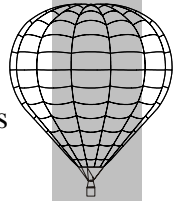

5.2.6 SOLO Fuel Manifold Assembly Removal

The fuel manifold is required when a standard Ultramagic 20kg or 30kg fuel cylinder is used in place of the special SOLO cylinder.

To remove the fuel manifold assembly, refer to figure 13 and proceed as follows:

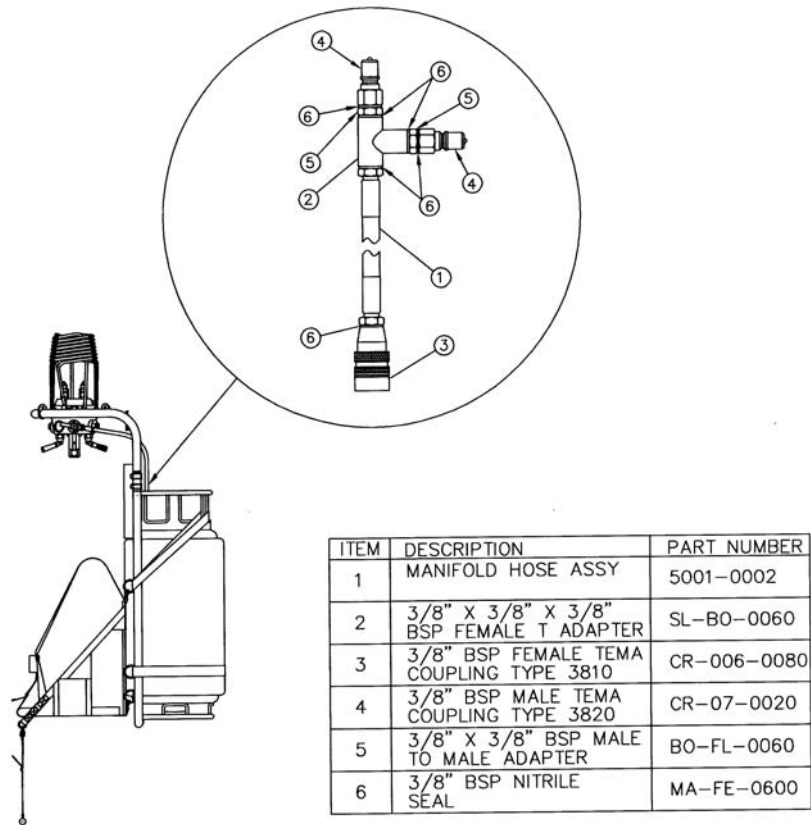

FIGURE 13
FUEL MANIFOLD ASSEMBLY

- Ensure that the fuel cylinder is switched off.
- Completely vent the manifold of fuel by operating any of the burner main or liquid valves.
- Disconnect the manifold from the cylinder and from the burner hoses.
- The manifold may be further disassembled using open-ended spanners.

When re-assembling the manifold, ensure that the 3/8" BSP bonded washers are fitted in the correct positions.

Re-assembled manifolds must be pressure tested. Connect a 7 bar (100 psi) air supply to any of the Tema couplings. Check all joints using soapy water.

5.2.7 SOLO Headrest Assembly Removal

To remove the Solo headrest assembly, refer to figure 1 and proceed as follows:

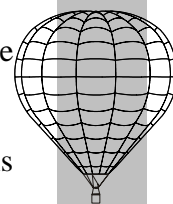

Release the Velcro straps securing the headrest to the main frame and withdraw the headrest.

Replacement is the reverse procedure to removal. Make sure that the headrest is positioned so that it provides adequate head protection from the main frame.

5.2.8 SOLO Footrest Assembly Removal

The footrest may be removed from the harness assembly by disconnecting the snap hooks from the “D” rings fitted on the harness side.

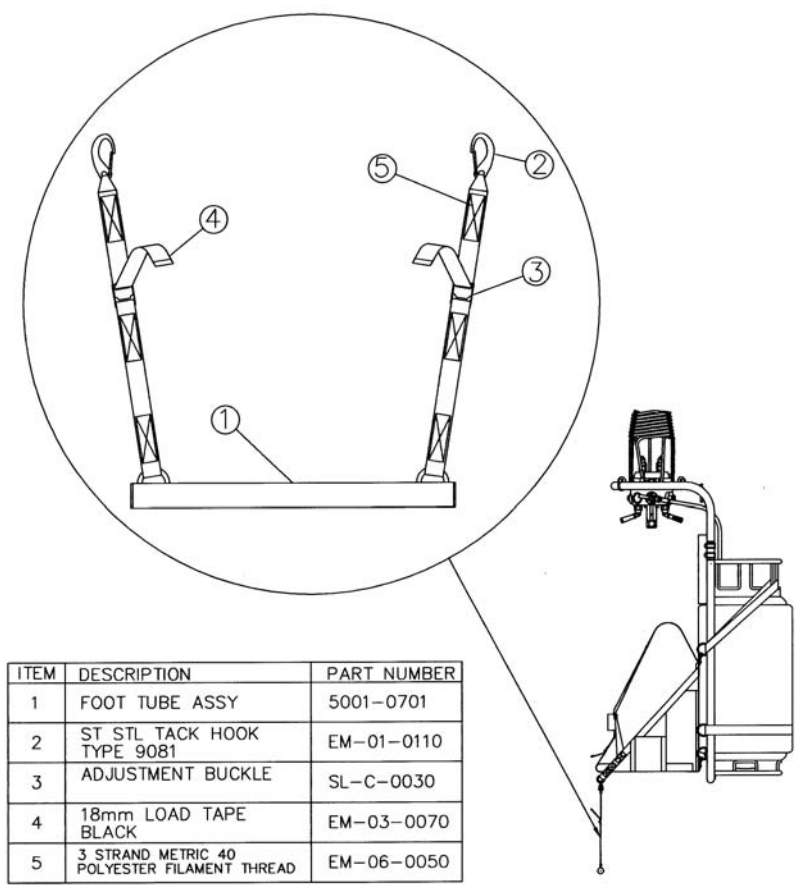

FIGURE 14
FOOT REST ASSEMBLY

Repairs to the load tape must be made in accordance with the requirements of the Ultramagic Maintenance Manual. All sewn joints must be fully gated.

5.3 DUO

5.3.1 DUO Main Frame Assembly Removal

To remove the DUO main frames, refer to Figure 1.A and proceed as follows:

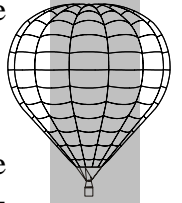

- Turn off the cylinder fuel valves and make sure that the burner and fuel hoses are fully vented of fuel.
- Disconnect the fuel hoses from the cylinders.
- Release and remove the eight, shaft locking pins (item 8, figure 1.A).
- Remove the burner, burner frame assembly and interface tubes as one from the main frames. Place the burner and burner frame assembly carefully on a non-abrasive surface.
- Release the Velcro straps securing the headrest to the main frames. Remove the headrest from the main frame.
- Undo and remove the four quick links securing each harness assembly to the main frames. Remove the harness and footrest assemblies as one.
- Undo and remove the lower tank strap.
- Undo and remove the upper tank straps.
- Undo and release the two special straps.
- Remove the cylinders from the main frames. Take care to prevent the main frames from falling over when the cylinders are removed.
- Undo and remove the four special lock pins (item 21, figure 1.A) securing each of the two hinge assemblies to the main frames. Remove the hinge assemblies.

Re-assembly is generally the reverse procedure to disassembly. Note that when re-assembling; take care to ensure that the quick links securing the harnesses are secure and that the gates are closed and tight. In addition, make sure that all eight shaft-locking pins are fitted and that the spring retaining clips are closed. Ensure that all pins securing the interface tubes to the suspension blocks are fitted and locked.

5.3.2 DUO Harness Assembly Removal

See SOLO harness removal section 5.2.2.

5.3.3 DUO Cylinder Removal

The procedure to remove the cylinders from the DUO is as for the SOLO with the following additional instruction:

- Prior to releasing the cylinder restraint straps, release the two special straps.

Further cylinder maintenance is as described in the Ultramagic Maintenance Manual.

5.3.4 DUO Burner Assembly

5.3.4.1 DUO Burner Colour Coding

The SOLO and DUO burners are provided with colour coded controls and hoses to assist with the correct fuel management of the equipment. Whenever maintenance work is carried out on the burner, ensure that correct colour coding is maintained. Controls and hoses coloured red are dedicated to the burner left hand fuel circuit. Controls and hoses

coloured blue are dedicated to the burner right hand fuel circuit. If in doubt, contact Ultramagic.

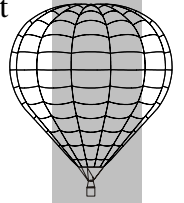

5.3.4.2 Removal of DUO Burner from Burner Frame

To remove the DUO burner from the burner frame, refer to Fig 15 and proceed as follows:

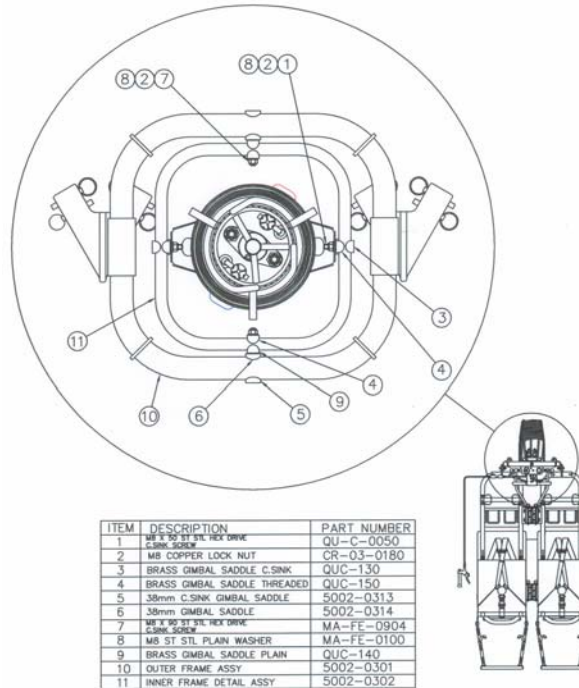

FIGURE 15
BURNER REMOVAL

- Detach the burner frame from the rest of the equipment (see section 5.3.1) and work on the bench.
- Before removing any burner support fixings, ensure that the burner is supported.
- Using a 5mm Allen key and a 13mm open-ended spanner undo and remove the two M8 countersink screws and copper lock nuts items 1 and 2 securing the burner support brackets to the inner frame.
- Withdraw the burner from the inner frame. Note that the brass saddles items 3 and 4 will now be loose.

Replacement is generally the reverse procedure of removal. When replacing the burner, make sure that the threaded brass saddle item 4 is placed in the correct position. Ensure that the copper lock nuts are used. Plain nuts must not be used in these positions. If the locking action of the copper lock nuts feels weak, replace with new ones.

5.3.4.3 DUO Burner Coil Assembly Removal

To prevent the risk of damage to the burner mounting brackets, it is recommended that the burner be removed from the burner frame before removing the coil. Refer to section 5.3.4.2.

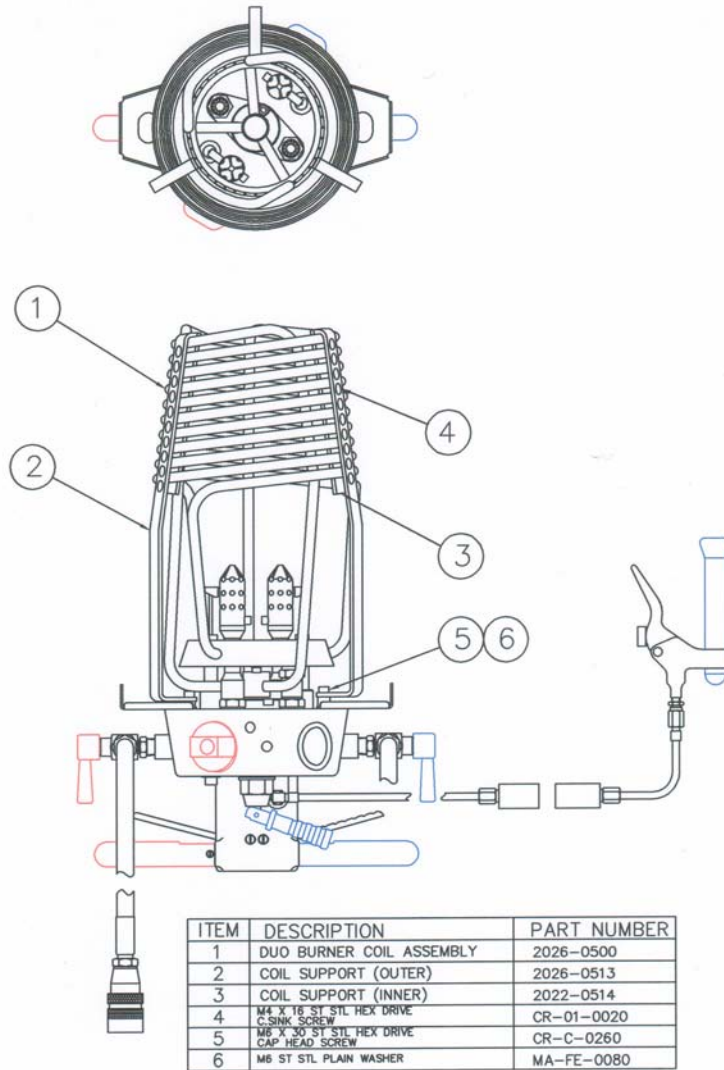
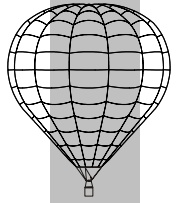

FIGURE 16
DUO BURNER COIL

Removal of the DUO burner coil assembly is the same procedure as for the SOLO burner coil (see section 5.2.4.4).

Note that the SOLO and DUO coil assemblies are different sizes and must not be interchanged.

5.3.4.4 DUO Burner Coil Support Removal

To remove the coil supports, refer to figure 16 and proceed as follows:

- Remove the coil assembly as described in section 5.3.4.3.
- Using a 3mm AF Allen key, undo and remove the ten, countersink screws item 14 securing the outer coil support item 12 to the inner coil support item 13.
- Remove the outer and inner coil supports.

Replacement is generally the reverse procedure of removal. When replacing the inner and outer coil supports, it will be necessary to position them correctly on the coil. Use the mounting hole in the valve block to align the supports. Ensure that all fixing screws are secure and tight.

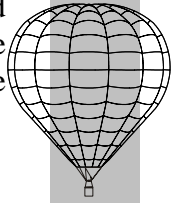

5.3.4.5 DUO Burner Mounting Bracket Removal

Remove the burner from the burner frame as described in section 5.3.4.2. Removal of the DUO burner mounting brackets is the same procedure as for the SOLO (see section 5.2.4.6). Note however that both DUO mounting brackets are identical and do not incorporate the interface to the gimbal lock pin.

5.3.4.6 DUO Hydraulic Valve Removal

Removal of the DUO Hydraulic Valve Assembly is identical to the process whereby the SOLO Hydraulic Valve Assembly is removed (see section 5.2.4.7). Note that the hydraulic valve is fitted as standard to the DUO burner.

5.3.4.7 DUO Burner Fuel Hose Removal

Removal of the DUO burner fuel hoses is identical to the process whereby the SOLO fuel hoses are removed (see section 5.2.4.8). Note that the DUO burner fuel hose diameter is larger than that used on the SOLO and must not be interchanged.

The fuel hose type is as specified in the Ultramagic Maintenance Manual.

5.3.5 DUO Burner Frame

5.3.5.1 DUO Outer Burner Frame Removal

To remove the DUO outer burner frame, refer to Figures 1 and 17 and proceed as follows:

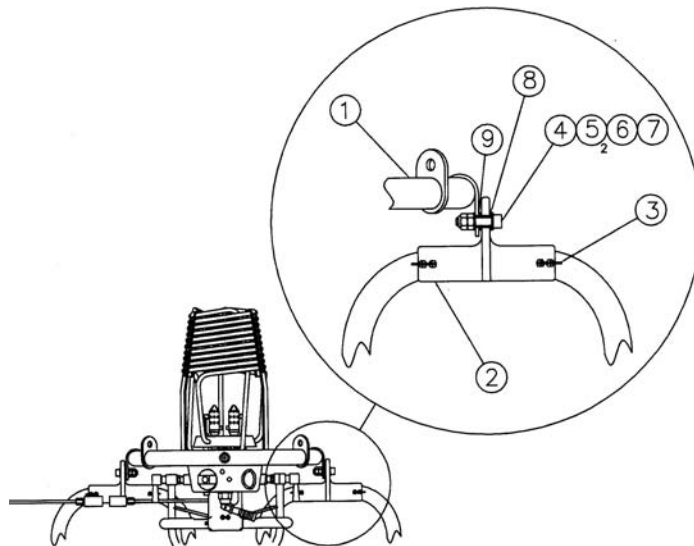
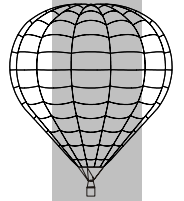

ITEM	DESCRIPTION	PART NUMBER
1	OUTER FRAME ASSY	5002-0301
2	SUSPENSION BLOCK	5002-0011
3	LOCK PIN (45MM)	QU-C-0715
4	M10 X 45 ST STL CAP HEAD BOLT	MA-FE-0403
5	M10 ST STL PLAIN WASHER	CR-C-0160
6	M10 ST STL PLAIN NUT	MA-FE-0410
7	M10 ST STL COPPER LOCK NUT	CR-03-0180
8	SUSPENSION BEARING (LONG)	5002-0012
9	SUSPENSION BEARING (SHORT)	5002-0013

FIGURE 17
OUTER BURNER FRAME REMOVAL

- Ensure that the equipment is properly supported.
- Undo and remove the eight shaft locking pins (item 8 Figure 1.A) securing the main frames to the four suspension tubes.
- Lift the burner frame off the main frames.
- Remove the eight lock pins (item 17, Figure 1.A) securing the interface tubes to the suspension blocks.
- Remove the interface tubes from the suspension blocks.
- Remove the inner frame and burner as described in section 5.3.5.2.
- Using an 8mm Allen key and a 17mm open ended spanner, undo and remove the two M10 cap head bolts, plain nut, copper lock nut and plain washers (items 4, 5, 6 and 7 Figure 17) securing the left hand suspension block to the bracket on the burner frame. Withdraw the block. Remove the two bushes (items 8 and 9 Figure 17) from inside the holes in the block web and the two bushes from inside the bracket on the burner frame.
- Remove the right hand suspension block as described above.

Replacement is generally the reverse procedure of removal. When re-assembling the suspension blocks to the frame, make sure that the bushes are fitted correctly in the suspension blocks and in the frame brackets. Re-fit the copper lock nuts. Plain nuts must not be used in these positions. If the copper lock nut locking action feels weak, replace with new ones.

Note: The four bolts securing the Suspension Block to the Burner Frame are structural. Under no circumstances may any bolts other than those supplied by Ultramagic be fitted in these positions.

If the burner or inner frame has been removed from the outer frame, ensure that the burner orientation is correct see section 5.3.4.1.

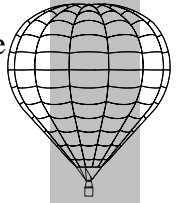

5.3.5.2 DUO Inner Burner Frame Removal

To remove the DUO inner burner frame refer to Fig 15 and proceed as follows:

- Detach the burner frame from the rest of the equipment as described above and work on the bench.
- Before removing any burner support fixings, ensure that the burner weight is supported.
- Remove the burner from the inner frame as described in section 5.3.4.2.
- Using a 5mm Allen key and a 13mm open-ended spanner undo and remove the two M8 countersink screws item 7, copper lock nuts item 2 and plain washers item 8 securing the inner frame to the outer frame.

Replacement is generally the reverse procedure of removal. When replacing the inner frame, make sure that the threaded brass saddle item 4 is placed in the correct position. Ensure that the copper lock nuts are used. Plain nuts must not be used in these positions. If the locking action of the copper lock nuts feels weak, replace with new ones.

5.3.6 Interface Tube Removal

Removal of the Interface Tubes is as described in section 5.3.5.1.

5.3.7 DUO Mirror Assembly Removal

To remove the DUO mirror assemblies, refer to Figure 18 and proceed as follows:

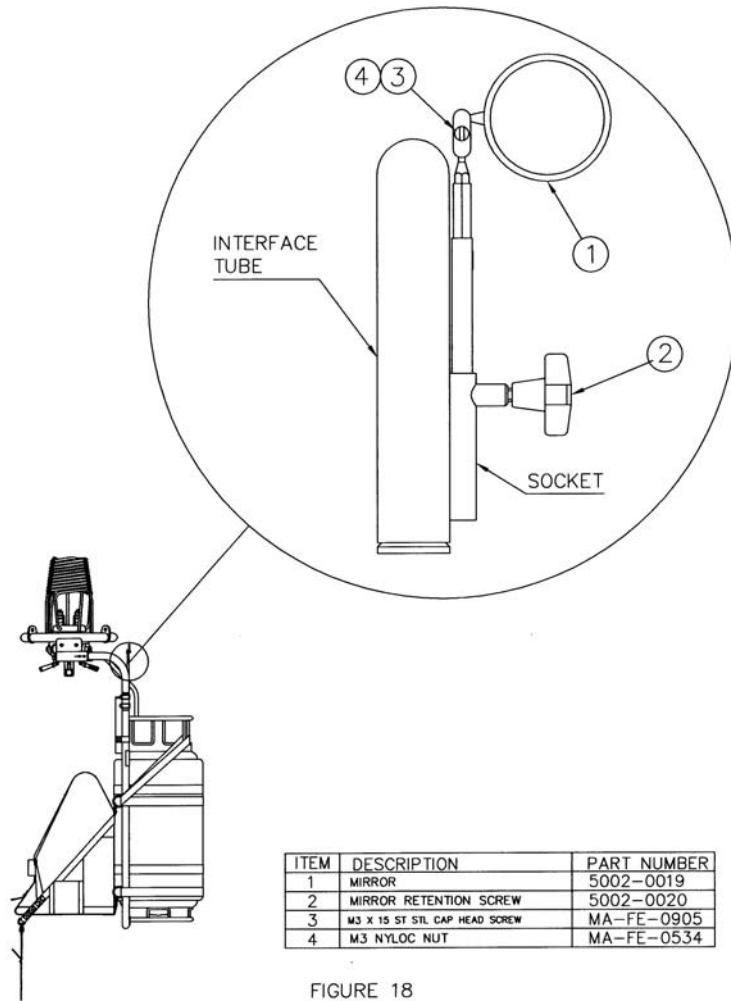
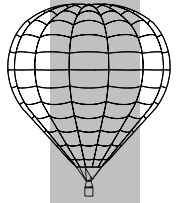

ITEM	DESCRIPTION	PART NUMBER
1	MIRROR	5002-0019
2	MIRROR RETENTION SCREW	5002-0020
3	M3 X 15 ST STL CAP HEAD SCREW	MA-FE-0905
4	M3 NYLOC NUT	MA-FE-0534

FIGURE 18
MIRROR REMOVAL

- Loosen the thumb wheel screw fitted to the side of the mirror support socket.
- Withdraw the mirror.

Further maintenance is limited to tightening or replacement of the mirror head swivel joint fixings.

Replacement is generally the reverse procedure of removal.

5.3.8 DUO Hinge Assembly Removal

Prior to removing the hinge assemblies, ensure that the equipment is properly supported.

To remove the hinge assemblies, refer to Figure 19 and proceed as follows:

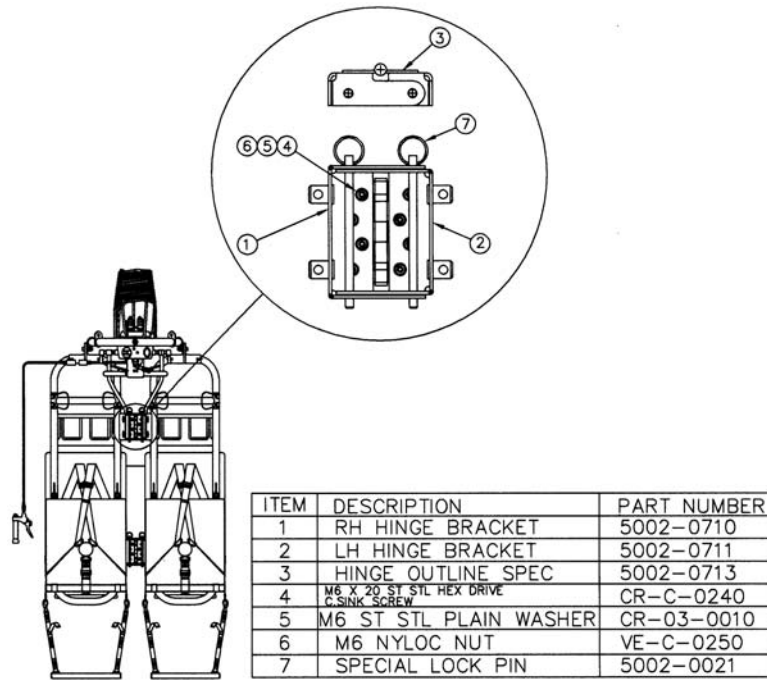
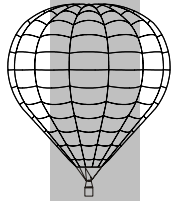

FIGURE 19
HINGE ASSEMBLY

- Remove the burner and burner frame as described in section 5.3.5.1.
- Slacken the two special straps linking the two fuel cylinders.
- Remove the four pins securing the upper hinge assembly to the left and right main frames.
- Withdraw the hinge assembly.
- Remove the two long pins from the hinge assembly.
- Repeat the above process for the lower hinge assembly.
- Using a 4mm Allen key and a 10mm spanner, undo and remove the eight countersink screws, nuts and washers securing the hinge to the left and right hinge brackets.

Re-assembly is generally the reverse process of removal.

5.3.9 DUO Headrest Assembly Removal

To remove the DUO headrest assembly, proceed as follows:

Release the Velcro straps securing the headrest to the main frames and withdraw the headrest.

Replacement is the reverse procedure to removal. Make sure that the headrest is positioned so that it provides adequate head protection from the main frame.

5.3.10 DUO Footrest Assembly Removal

See SOLO footrest assembly removal section 5.2.8.

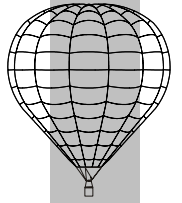

5.3.11 DUO Foam Spacer Assembly Removal

To remove the foam spacer assembly refer to Figure 1.A and proceed as follows:

- Release the two special straps linking the two fuel cylinders.
- Release the straps securing the foam spacer assembly to one of the cylinders.
- Withdraw the spacer from between the cylinders.
- Open the Velcro flap at the top of the spacer assembly and withdraw the foam block from inside.

Replacement is generally the reverse process of removal.

5.3.12 Special Strap Assembly Removal

To remove the two special strap assemblies, refer to figure 1.A and proceed as follows:

- Release the adjustment buckles securing the two halves of the upper and lower straps together.
- Slacken off but do not remove all the cylinder restraint straps. Take care to support the equipment at this stage to prevent overbalancing.
- Remove the special straps from the main frames by passing through the loop sewn on the strap.

Replacement is generally the reverse procedure of removal.

Section 6

6.0 Annual / 100 Hour Inspection Requirements

6.1 SOLO

6.1.1 General

The SOLO must be subjected to an inspection by an inspector approved by the national airworthiness authority in the state of registration. The inspection must be carried out every 12 months or 100 hours use, whichever is the sooner.

The inspection requirements detailed below are additional to those already specified in the appropriate sections of the Ultramagic Maintenance Manual.

6.1.2 SOLO Main Frame Assembly

- Carry out all checks detailed in Section 4.1.2 (Preventative Maintenance) of this Supplement.

6.1.3 SOLO Harness Assembly

Carry out all checks detailed in Section 4.1.3 (Preventative Maintenance).

6.1.4 SOLO Cylinder Assembly

- Carry out all checks detailed in the Ultramagic Flight Manual.
- Carry out all checks detailed in section 4.1.4 (Preventative Maintenance).
- Check that the fuel contents gauge is clearly visible and that the protective lens covering the gauge face is not badly scratched or in any state which impairs the clear view of the gauge face.
- Check for the correct function of the fuel contents gauge and that full deflection of the gauge pointer is achievable. (Note that for special SOLO fuel cylinder fitted with dual fuel feeds, the orientation of the gauge within the cylinder is very important. Incorrect assembly can cause the gauge float to catch on the liquid feed dip tubes preventing the gauge from correctly monitoring the fuel content).

6.1.5 SOLO Burner Assembly

- Carry out all checks detailed in the Ultramagic Flight Manual.
- Carry out all checks detailed in Section 4.1.5 (Preventative Maintenance).
- Check that the burner mounting brackets are in good condition. Badly distorted brackets must be replaced.

6.1.6 SOLO Burner Frame Assembly

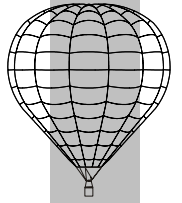

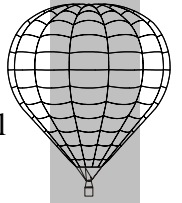

- Carry out all checks detailed in the Ultramagic Flight Manual
- Carry out all checks detailed in Section 4.1.6 (Preventative Maintenance).
- Check that the burner mounting fixings are secure and that the burner gimbal friction is satisfactory.
- Check for the correct function of the gimbal lock pin.

6.1.7 SOLO Mirror Assembly

- Check the condition of the reflective surface. If the surface provides a poor reflection, then the mirror must be replaced.
- Check the fit of the mirror in the mounting bushes fitted on the burner frame. The fit must be positive and secure and allow for mirror adjustment. Replace worn mirror mounting bushes.

6.1.8 SOLO Fuel Manifold Assembly

- Check the condition of the hose. If the hose shows signs of abrasion, kinking or other forms of damage, it must be replaced.
- Air pressure test the complete assembly and check for leaks using soapy water.

6.1.9 SOLO Headrest Assembly

- Check that the headrest assembly is fitted and that the attachment is secure.
- Check the general condition of the headrest. Badly damaged or worn fabric must be repaired or replaced.

6.1.10 SOLO Footrest Assembly

- Check the condition of the load tapes and all sewn joints.
- Check that the foot tube assembly is in good condition.
- Check that the adjustment buckles are in good condition, function correctly and grip the load tape.

6.1.11 SOLO Cylinder Straps

- Check the general condition of all straps. Straps showing signs of wear must be replaced.
- Check the function of the adjustment buckle and that it functions correctly and securely grips the webbing.

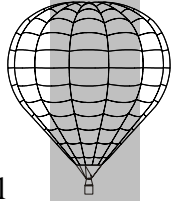

6.2 DUO Annual / 100 Hour Inspection Requirements

6.2.1 General

The DUO must be subjected to an inspection by an inspector approved by the national airworthiness authority in the state of registration. The inspection must be carried out every 12 months or 100 hours use, whichever is the sooner.

The inspection requirements detailed below are additional to those already specified in the appropriate sections of the Ultramagic Maintenance Manual.

6.2.2 DUO Main Frames

- Carry out all checks detailed in Section 4.2.2 (Preventative Maintenance) of this Supplement.
- Check the welded joints securing the hinge support blocks to the main frame sides.

6.2.3 DUO Harness Assemblies

Carry out all checks detailed in Section 4.2.3 (Preventative Maintenance) of this Supplement.

6.2.4 DUO Cylinder Assemblies

- Carry out all checks detailed in the Ultramagic Flight Manual.
- Carry out all checks detailed in section 4.2.4 (Preventative Maintenance).
- Check that the fuel contents gauge is clearly visible and that the protective lens covering the gauge face is not badly scratched or in any state which impairs the clear view of the gauge face.

6.2.5 DUO Burner Assembly

- Carry out all checks detailed in the Ultramagic Flight Manual
- Carry out all checks detailed in Section 4.2.5 (Preventative Maintenance).
- Check that the burner mounting fixings are secure and that the burner gimbal friction is satisfactory.
- Check that the inner frame mounting fixings are secure and that the inner frame gimbal action is satisfactory.

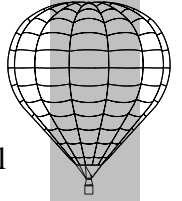

6.2.6 DUO Burner Frame Assembly

- Carry out all checks detailed in the Ultramagic Flight Manual
- Carry out all checks detailed in Section 4.2.6 (Preventative Maintenance).
- Check that the burner mounting fixings are secure and that the burner gimbal friction is satisfactory.
- Check that the inner frame mounting fixings are secure and that inner frame gimbal friction is satisfactory.

6.2.7 DUO Interface Tubes

- Carry out all checks detailed in Section 4.2.7 (Preventative Maintenance).

6.2.8 Duo Mirror Assemblies

- Check the condition of the reflective surface. If the surface provides a poor reflection, then the mirror must be replaced.
- Check the mirror head adjustment. Make sure it is secure and tight. Re-tighten if necessary.
- Check the fit of the mirrors in the sockets fitted to the interface tubes. Ensure that the mirrors can be made secure in the sockets using the thumb wheel screws.

6.2.9 DUO Hinge Assemblies

- Carry out all checks detailed in section 4.2.9 Preventative Maintenance.

6.2.10 DUO Headrest Assemblies

- Check that the headrest assembly is fitted and that the attachment is secure.
- Check the general condition of the headrest. Badly damaged or worn fabric must be repaired or replaced.

6.2.11 DUO Footrest Assembly

- Check the condition of the load tapes and all sewn joints.
- Check that the foot tube assembly is in good condition.
- Check that the adjustment buckles are in good condition, function correctly and grip the load tape.

6.2.12 DUO Foam Spacer Assembly

- Check the condition of the load tapes and that their attachment to the fabric bag is secure.
- Check for the correct function of the adjustment buckles.

- Check that the correct foam spacer assembly is fitted for the cylinder size.
- Check that the foam block has not taken a permanent set and that it remains compressible when fitted between the two cylinders.
- Check that foam layers used to form the foam block remain bonded together.

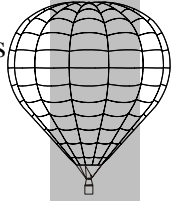

6.2.13 DUO Special Strap Assemblies (DUO Only)

- Check that the load tape loops are securely attached to the main strap and that all stitching is in good condition.
- Check the general condition of the strap. Straps showing signs of webbing wear must be replaced.
- Check the function of the adjustment buckle and that it functions correctly and securely grips the webbing.

6.2.14 DUO Cylinder Straps

- Check the general condition of all straps. Straps showing signs of wear must be replaced.
- Check the function of the adjustment buckle and that it functions correctly and securely grips the webbing.

Section 7 300 Hour / Triennial Inspection requirements

7.1 SOLO

7.1.1 General

The SOLO must be subjected to the following inspection by an inspector approved by the national airworthiness authority in the state of registration. The following inspection must be carried out every 36 months or 300 hours use, whichever is the sooner.

7.1.2 Non-destructive Testing

The areas indicated in Figure 20 shall be subject to die-penetrant non-destructive testing. The test is designed to provide advanced warning of weld, joint or material deterioration. The test must be carried out by a suitably qualified organisation.

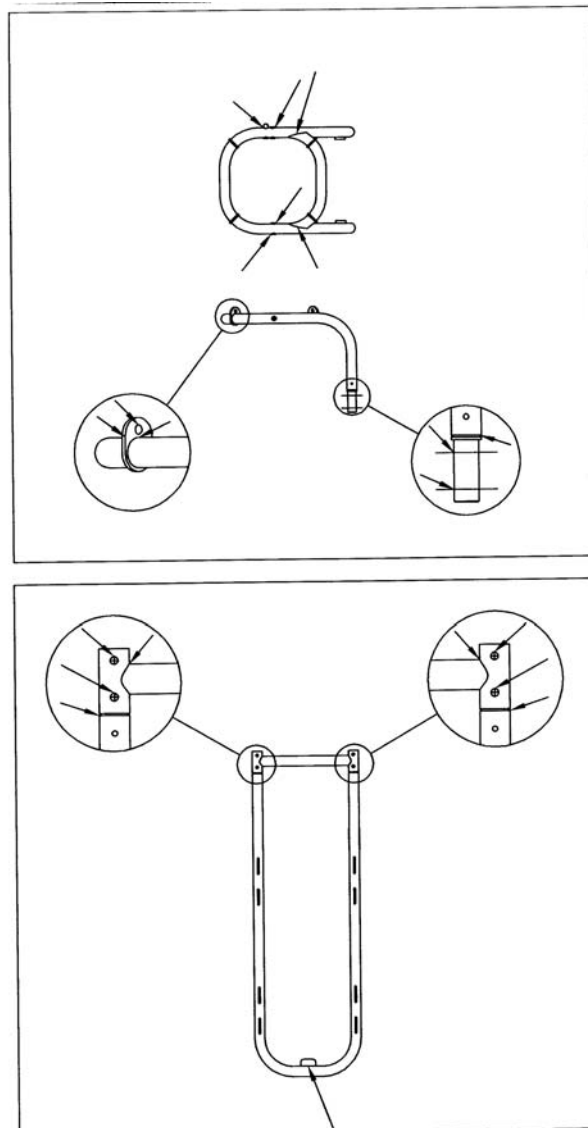
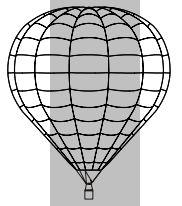

FIGURE 20
NON-DESTRUCTIVE TESTING REQUIREMENTS



S
4
S
O
L
O
-
D
U
O
B
A
L
L
O
N
S

Replace all shaft locking pins with new ones.

7.2 DUO

7.2.1 General

The DUO must be subjected to the following inspection by an inspector approved by the national airworthiness authority in the state of registration. The following inspection must be carried out every 36 months or 300 hours use, whichever is the sooner.

7.2.2 Non-Destructive Testing

The areas indicated in Figure 21 shall be subject to die-penetrant non-destructive testing. The test is designed to provide advanced warning of weld, joint or material deterioration. The test must be carried out by a suitably qualified organisation.

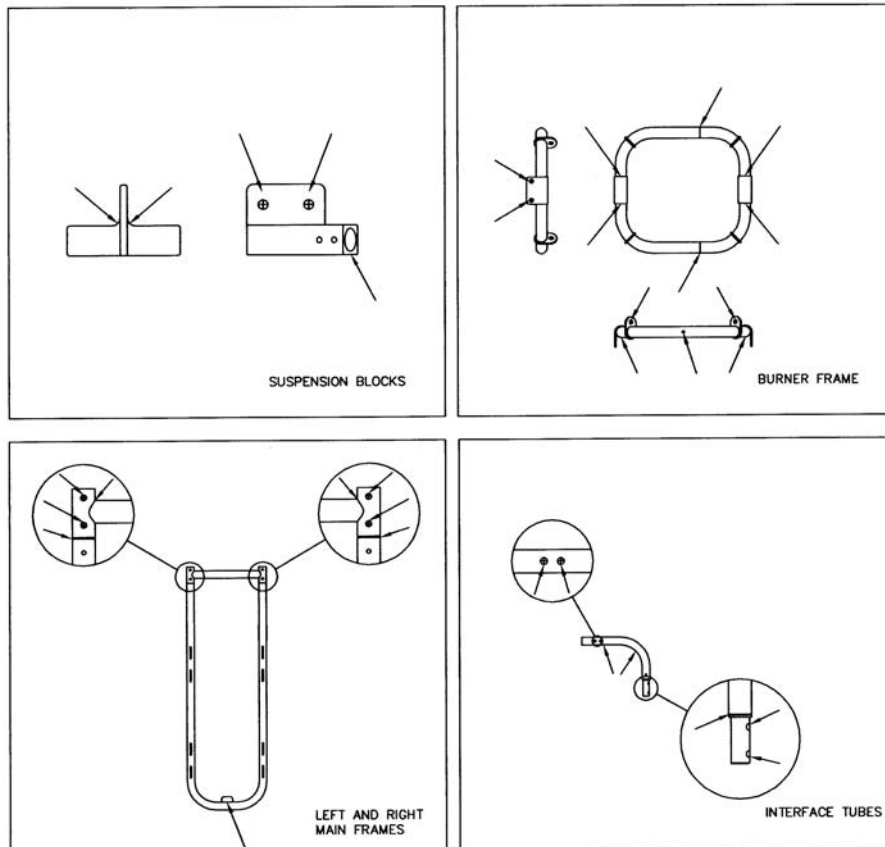
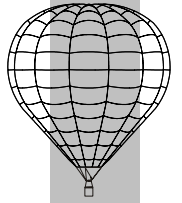

FIGURE 21
DUO NON-DESTRUCTIVE TESTING REQUIREMENTS

Replace all shaft locking pins with new ones.

Replace the four m10 bolts securing the burner frame to the suspension blocks with new bolts.



APPENDIX 1

SOLO Annual / 100 Hour Inspection Checklist

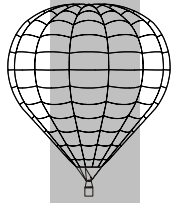

S
4
S
O
L
O
-
D
U
O
B
A
L
L
O
N
S

REQUIREMENT	REFERENCE	OKAY	COMMENTS
<u>Main Frame Assembly</u>			
Welded Joints	4.1.2		
Indentation	4.1.2		
Lock Pin Holes	4.1.2		
“D” Lugs	4.1.2		
Cylinder Retaining Plate	4.1.2		
Shaft Locking Pins	4.1.2		
Harness Assembly			
Load Tapes	4.1.3		
Load Tape Joints	4.1.3		
Load Tape Loops	4.1.3		
Fabric Wear	4.1.3		
Fabric Seams	4.1.3		
Quick Links	4.1.3		
Adjustment Buckles	4.1.3		
Quick Release Box	4.1.3		
Fuel Cylinder			
Maintenance Manual 100 Hour Inspection	Ultramagic Maintenance Manual		
Lower Ring	4.1.4		
Lower Ring Location with Retaining Plate	4.1.4		
Welded Joints	4.1.4		
Body Indentation	4.1.4		
Fuel contents Gauge	4.1.4		
SOLO Burner Assembly			
Maintenance Manual 100 Hour Inspection			
Coil Support Leg Fixing	4.1.5		
Burner Mounting Fixings	4.1.5		

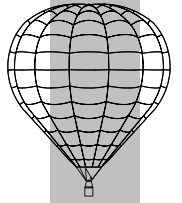

REQUIREMENT	REFERENCE	OKAY	COMMENTS
Hose Fixings	4.1.5		
Hydraulic Valve Function	4.1.5		
Mounting Brackets	4.1.5		
Isolation Valve Function	4.1.5		
Burner Frame Assembly			
Maintenance Manual 100 Hour Inspection			
Welded Joints	4.1.6		
Indentation	4.1.6		
Pin Holes	4.1.6		
Suspension Lugs	4.1.6		
Fixings and Gimbal Friction	6.1.6		
Gimbal Lock Pin	6.1.6		
Mirror Condition and Mounting	6.1.6		
Mirror Assembly			
Reflective Surface	6.1.7		
Mirror Fit	6.1.7		
Fuel Manifold Assembly			
Hose Condition	6.1.8		
Pressure Test	6.1.8		
Headrest Assembly			
Attachment	6.1.9		
Fabric Condition	6.1.9		
Footrest Assembly			
Load Tape and Joints	6.1.10		
Foot Tube Condition	6.1.10		
Adjustment Buckle Function and Condition	6.1.10		
Cylinder Straps			
Strap Condition	6.1.11		
Buckle Function	6.1.11		

REQUIREMENT	REFERENCE	OKAY	COMMENTS
Non-destructive Test (300 Hour / Triennial)			
Die-penetrant Test	7.1.2		
Replace Shaft Locking Pins	7.1.2		

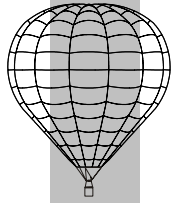

**S
4
S
O
L
O
-
D
U
O
B
A
L
L
O
N
S**

Appendix 2

DUO 100 Hour / Annual Inspection Checklist

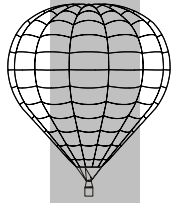

S
4
S
O
L
O
-
D
U
O
B
A
L
L
O
N
S

REQUIREMENT	REFERENCE	OKAY	COMMENTS
<u>Main Frame Assemblies</u>			
Welded Joints	4.2.2 and 4.1.2		
Indentation	4.2.2 and 4.1.2		
Lock Pin Holes	4.2.2 and 4.1.2		
“D” Lugs	4.2.2 and 4.1.2		
Cylinder Retaining Plate	4.2.2 and 4.1.2		
Shaft Locking Pins	4.2.2 and 4.1.2		
Hinge Support Block Welded Joints	6.2.2		
Harness Assembly			
Load Tapes	4.2.3 and 4.1.3		
Load Tape Joints	4.2.3 and 4.1.3		
Load Tape Loops	4.2.3 and 4.1.3		
Fabric Wear	4.2.3 and 4.1.3		
Fabric Seams	4.2.3 and 4.1.3		
Quick Links	4.2.3 and 4.1.3		
Adjustment Buckles	4.2.3 and 4.1.3		
Quick Release Box	4.2.3 and 4.1.3		
Fuel Cylinder			
Maintenance Manual 100 Hour Inspection	Ultramagic Maintenance Manual		
Lower Ring	4.2.4 and 4.1.4		
Lower Ring Location with Retaining Plate	4.2.4 and 4.1.4		
Welded Joints	4.2.4 and 4.1.4		
Body Indentation	4.2.4 and 4.1.4		
Fuel contents Gauge	4.2.4 and 4.1.4		
DUO Burner Assembly			
Maintenance Manual 100 Hour Inspection			
Coil Support Leg	4.2.5		

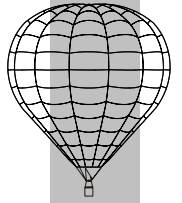

REQUIREMENT	REFERENCE	OKAY	COMMENTS
Fixing			
Burner Mounting Fixings	4.2.5		
Hose Fixings	4.2.5		
Hydraulic Valve Function	4.2.5		
Mounting Brackets	4.2.5		
Isolation Valve Function	4.2.5		
DUO Burner Frame Assembly			
Maintenance Manual 100 Hour Inspection			
Welded Joints	4.2.6		
Indentation	4.2.6		
Pin Holes	4.2.6		
Suspension Lugs	4.2.6		
Fixings and Gimbal Friction	6.2.6		
Interface Tubes			
Welded Joints	4.2.7		
Indentation	4.2.7		
Lock Pins	4.2.7		
Lock Pin Holes	4.2.7		
Mirror Assembly			
Reflective Surface	6.2.8		
Mirror Fit	6.2.8		
Hinge Assembly			
Fixings Secure	4.2.9		
Distortion and Cracking	4.2.9		
Lock Pin Condition	4.2.9		
Headrest Assembly			
Attachment	6.2.10		
Fabric Condition	6.2.10		
Footrest Assembly			
Load Tape and Joints	6.2.11		
Foot Tube Condition	6.2.11		

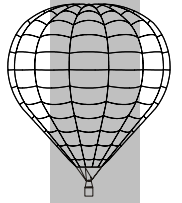

REQUIREMENT	REFERENCE	OKAY	COMMENTS
Adjustment Buckle Function and Condition	6.2.11		
Foam Spacer Assembly			
Load Tape Condition	6.2.12		
Adjustment Buckle Function	6.2.12		
Correct Size Spacer	6.2.12		
Permanent Set	6.2.12		
Foam Layer Bonding	6.2.12		
Special Strap Assembly			
Loop Condition	6.2.13		
Webbing Condition	6.2.13		
Buckle Function	6.2.13		
Cylinder Straps			
Strap Condition	6.2.14		
Buckle Function	6.2.14		
Non-destructive Test (300 Hour / Triennial)			
Die-penetrant Test	7.2.2		
Replace Shaft Locking Pins and M10 Bolts	7.2.2		