

Supplement 10 - Ultramagic Disabled Passenger Baskets

10.1 General Information

This supplement details the instructions and limitations necessary to ensure the safe operation, maintenance and continued airworthiness of Ultramagic baskets when fitted with the special Disabled Passenger carrying options.

Disabled passenger carrying is accomplished using either a special fixed seat or the Passenger's wheelchair if preferred

The fixed seat may be fitted to a variety of Ultramagic baskets of different sizes and configurations. Depending upon the basket size, more than one seat may be fitted. The seat is provided with a rotating bearing allowing the seat to orientate for the purposes of passenger loading or with an electric version of the seat. Special quick release fixings allow removal of the seat from two rails secured to the basket floor.

Provided that sufficient room exists within the basket, the floor rails may be used to secure a wheelchair, in place of the seat, should the passenger prefer. Special restraint straps and a headrest are required for this option.

The fixed seat option may be seen in Figure 1.

10.2 Limitations of Use

10.2.1 Introduction

The following limitations are additional to those already stated in the Flight Manual.

10.2.2 Meteorological Conditions

The maximum surface wind speed is 10 knots. When carrying disabled passengers, do not fly in any condition, which may cause the basket to tip on its side during landing.

10.2.3 Crew

No more than one person may occupy the seat or wheelchair at any one time.

10.2.4 Baskets

Rotation vents must be fitted to envelopes when carrying passengers in the fixed seat or wheelchair.

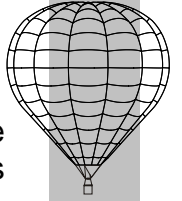

10.2.5 Landing Orientation

The basket must be aligned such that the disabled passenger's back faces the direction of landing. Landing with the basket orientation in any other direction is dangerous and could cause injury.

10.2.6 Passenger Safety

The final decisions relating to passenger safety and conditions suitable for a safe flight remain at all times with the pilot in command.

10.2.7 Passenger Harness

The passenger harness must remain attached and closed at all stages of takeoff, flight and landing.

10.2.8 Wheelchair Requirements

When a wheelchair is used to carry the passenger, the wheelchair must be approved for road transportation and conform to the requirements of ISO 7176 Section 19. Powered wheelchairs must not be used.

Sufficient space must be available within the basket to allow the wheelchair to be manoeuvred in to position without lifting and for the chair restraint straps to be fitted.

Only wheelchairs compatible with the restraint system may be used.

The headrest must always be fitted to the wheelchair.

10.2.9 Wheelchair Restraints

The wheelchair must be compatible with the strap restraint system. When secured, the wheelchair must be incapable of movement up and down, side-to-side and front to rear.

All four restraint straps must be fitted.

10.3 Emergency Procedures

No change.

10.4 Standard Procedures

The following procedures are additional to those already contained in the Flight Manual.

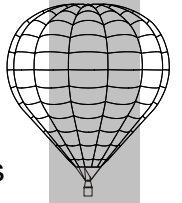

10.4.1 Seat and Wheelchair Installation

In order to prevent injury to the passenger and damage to the equipment, it is important that the following instructions are adhered to.

10.4.1.1 Fixed Seat

The fixed seat consists of a moulded rally seat mounted on a welded stainless steel frame. Two quick release seat fixtures are attached to the underside of the frame and are used to locate the seat assembly in the special track mounted on the basket floor. The fixtures allow rapid removal or installation of the seat assembly to the basket.

A pair of telescopic slides and a thrust bearing are fitted between the seat and the frame. Use of the slides and the bearing allow the seat to be rotated to a convenient position to facilitate passenger loading into the seat.

If the seat is fitted with the electric version, telescopic slides are substituted by a lifting platform.

To install the seat assembly into the basket, refer to figure 1 and proceed as follows:

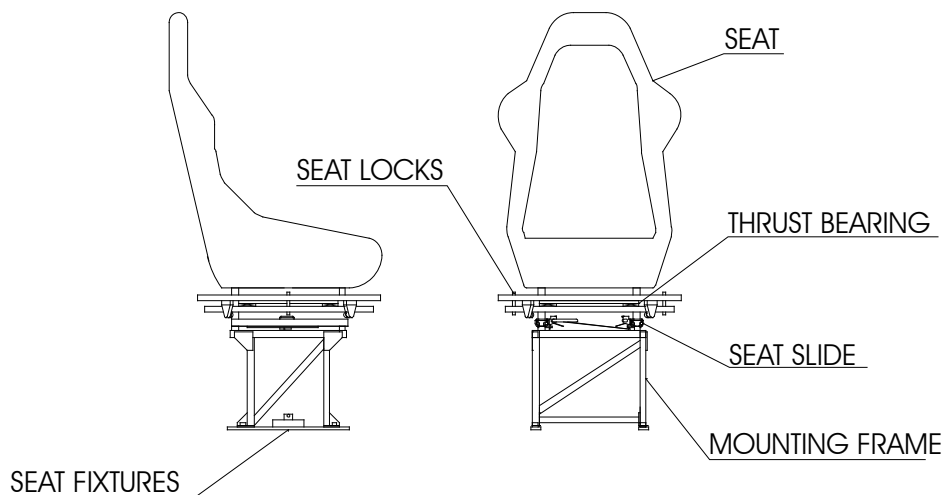

FIGURE 1
FIXED SEAT

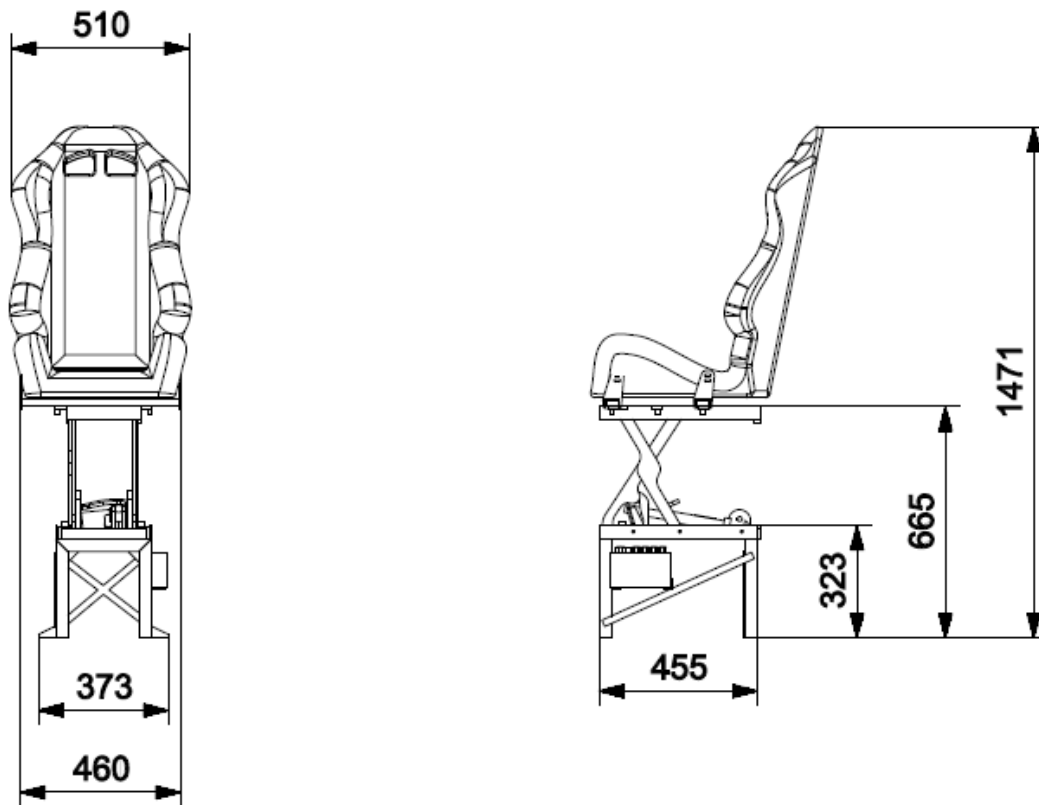
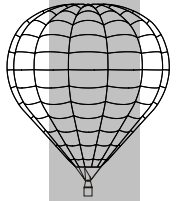
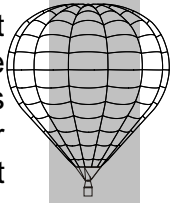

FIGURE 2
ELECTRIC VERSION SEAT

- When lifting the seat assembly, hold the mounting frame and not the seat. Using the seat to lift the assembly could cause damage to the thrust bearing or electric platform.
- Make sure that the telescopic slides fitted under the seat are fully closed and that the seat is positioned approximately centrally above the frame (skip for electric version).
- Raise the spring-loaded plungers in each of the seat fixtures.
- Place the seat assembly over the two floor mounted rails in the basket. Position the seat so that the rear of the seat is as close to the basket wall as possible. Engage the fixtures in the track. Rotate the plungers so that they are in the unrestrained position. Push the seat assembly back in the rails a short distance until the plungers engage fully in the track. Rotate the plungers to the "Lock" position.
- Operate the slides and move the seat backwards if necessary to ensure that the basket wall supports the rear of the seat (skip for the electric version).
- If the location of the nylon rod sockets is such that the basket wall cannot support the seat, use the foam spacer supplied and fit between the rear of the seat and the basket wall.
- Prior to loading the passenger, the balloon must be inflated and upright and the basket must be stationary on the ground. Ensure sufficient weight is added to the basket to prevent movement.





- The passenger may now be assisted into the seat. This is best accomplished by rotating the seat to face the basket door (not possible with electric version). To rotate the seat, remove the seat lock pins situated each side of the seat. Release the slide catch and slide the chair forward sufficiently to allow the seat to rotate. Rotate the seat so that it faces the basket door.
- Assist the passenger in to the seat.
- Rotate the seat back to its original position. Re-engage the seat lock pins. Operate the slide catch and push the chair back until the rear of the seat rests against the basket wall. Ensure that the slides are locked. (skip for electric version)
- Attach the two harness waist straps to the floor tracks. Connect one to the left track and the other to the right track. Ensure that they are locked in position. (skip for the electric version)
- Thread the passenger harness shoulder and waist straps through the apertures in the seat and secure the passenger in position. Make sure the harness is correctly adjusted and that the passenger is comfortable. Note that it is important to ensure that the harness and not the seat restrains the passenger weight.
- If necessary, fit the passenger footrest.

Note:

The thrust bearing fitted between the seat and the frame is designed to withstand compressive loads only. This means that the seat must be restrained for transportation and for flight. If the seat is not restrained, the thrust bearing may be damaged. During all phases of flight, the seat must be locked using the seat lock pins situated each side of the seat (not necessary with electric version) and the seat must be supported at the rear. For transportation, the seat must be restrained using the seat lock pins and by passing a strap through the two waist height harness apertures in the seat and securing to the frame below.

10.4.1.2 Wheelchair Installation

Wheelchair installation is best accomplished with the passenger already in the chair. Install and secure the wheelchair in accordance with the instructions contained in Appendix 1.

Fit the headrest in accordance with the instructions contained in Appendix 2.

Fit the passenger harness in accordance with the instructions contained in Appendix 3.

10.4.2 Preparation for Takeoff

The following pre-flight checks are additional to those already contained in the Ultramagic Flight Manual.

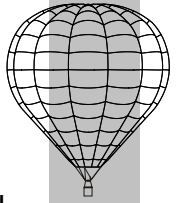

10.4.2.1 Fixed Seat

Ensure that the seat is securely attached to the floor mounted rails.

Check that the seat locks are in the locked position.

Check that the passenger harness is in good condition and is attached and secure.

Check that the rear of the seat is correctly supported.

Check that the basket door is closed and locked.

10.4.2.2 Wheelchair

Ensure that the wheelchair is correctly secured to the basket using the four restraint straps.

Check that restraint straps and the passenger harness are in good condition.

Check that the passenger harness is attached and secure.

Check that the headrest is secure and correctly adjusted.

Check that the basket door is closed and locked. Ensure that the lock bar is fully inserted. The door may be seen in Figure 2.

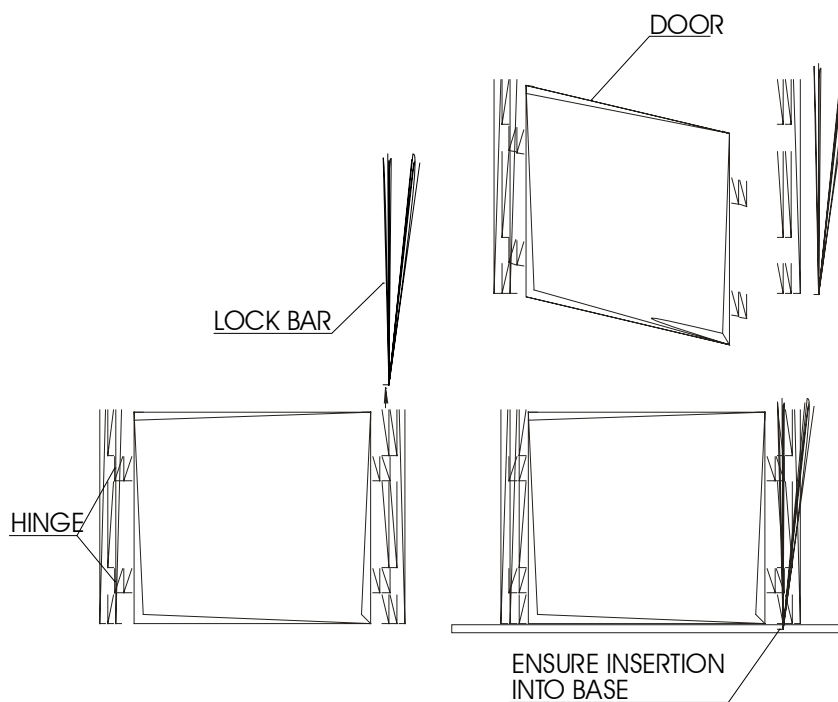

FIGURE 2
BASKET DOOR LOCKING ARRANGEMENT

10.4.3 Unloading Passengers

Prior to unloading passengers in the fixed seat or passengers in a wheelchair, make sure that the basket is stationary and in the upright position.

10.5 Loading

No change

10.6 Balloon and Systems Description

10.6.3 Dimensions and Weights

DISABLED PASSENGER FIXED SEAT

Model Removable Chair Assembly Type 3101-0800

Mass 27kg

DISABLED PASSENGER FIXED SEAT – ELECTRIC VERSION

Model Removable Chair Assembly Type 3101-0800

Mass XX kg

10.7 Balloon Handling, Maintenance and Care

Instructions for the Maintenance, Handling and Care of the equipment associated with the carrying of disabled passengers are contained in the Maintenance Manual Supplement No. 10.

10.8 Other Manufacturer's Equipment

No change.

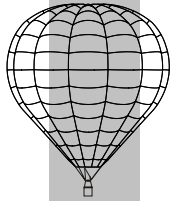

**S
1
0
D
I
S
A
B
L
E
D
P
A
S
S
E
N
G
E
R
B
A
S
K
E
T**

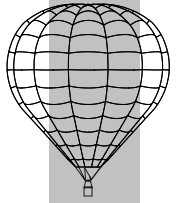

APPENDIX 1

FOUR POINT WHEELCHAIR TIE-DOWN RESTRAINTS

INSTALLATION PROCEDURE

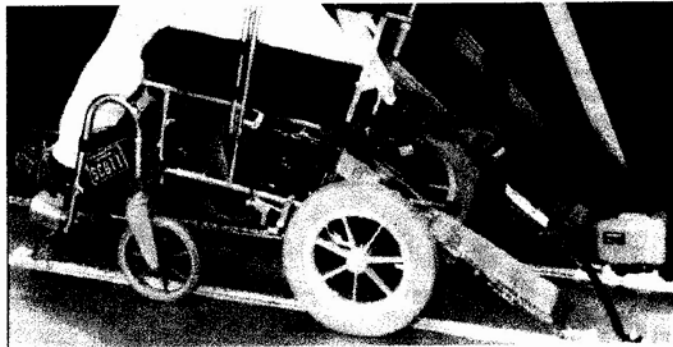

A. LIMITATIONS OF USE

1. THIS PRODUCT HAS BEEN DESIGNED AS A FOUR POINT TIE-DOWN SYSTEM.
2. FRONT OR REAR STRAPS MUST NOT BE USED ON THEIR OWN.
3. AN INDEPENDENT OCCUPANT RESTRAINT MUST ALWAYS BE USED FOR THE SEAT OCCUPANT.
4. THIS RESTRAINT SYSTEM MAY NOT BE SUITABLE FOR SOME BUGGY-TYPE WHEELCHAIRS, IF IN DOUBT PLEASE CONTACT ULTRAMAGIC OR THE WHEELCHAIR MANUFACTURER.

B. INSTALLATION

1. ENSURE THAT THE WHEELCHAIR IS APPROPRIATE FOR THE TIE DOWN BEING USED.
2. POSITION THE WHEELCHAIR SYMMETRICALLY ABOUT THE TWO RAILS AND WITH THE BACK OF THE WHEELCHAIR FACING THE DIRECTION OF LANDING. IF THE BASKET IS POSITIONED ON A SLOPE, ENSURE THE WHEELCHAIR CANNOT ROLL.

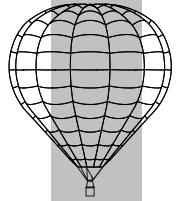

ATTACHING THE FRONT STRAPS WWR/LRF

1. ATTACH THE FRONT STRAPS INTO RAIL (FIG A),
2. YELLOW PLUNGERS FACING THE FRONT OF BASKET.
3. MATCH THE FEET ON THE CLIP WITH THE CUT-OUT SECTIONS OF THE RAIL, INSERT INTO THE RAIL AND THEN MOVE SLIGHTLY BACKWARDS OR FORWARDS UNTIL THE YELLOW PLUNGER DROPS AND LOCKS INTO THE RAIL. CHECK THAT THE FITTING IS SECURE.
4. INSTALL THE SECOND CLIP, THE POSITION OF THIS MUST BE IN LINE WITH THE FIRST.
5. WITH BUCKLES FACING OUTWARDS. CONNECT THE FRONT STRAPS TO THE FRONT VERTICAL FRAMEWORK OF THE WHEELCHAIR ABOVE THE FRONT CASTERING WHEELS, (FIG B). IMPORTANT, CHECK BOTH SETS OF BUCKLE AND TONGUE ARE FULLY CLIPPED TOGETHER.
6. PULL WHEELCHAIR BACK TO TENSION FRONT TIE-DOWN STRAPS AND APPLY WHEELCHAIR BRAKES IF FITTED.

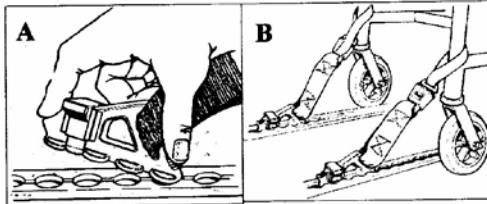

ATTACHING THE REAR STRAPS

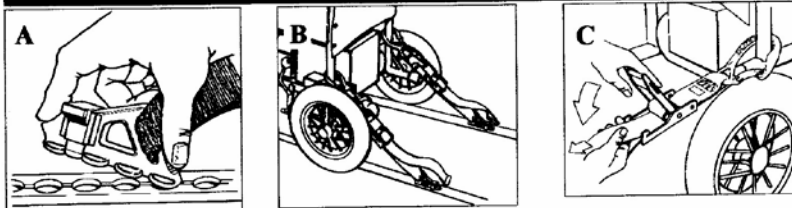

KARABINER VERSION

1. ATTACH REAR STRAPS INTO RAIL (FIG A) APPROXIMATELY 300 MM BEHIND THE WHEELCHAIR BACKREST.
2. NOTE: YELLOW PLUNGERS MUST FACE REAR. RELEASE OVER-CENTRE BUCKLES.
3. ATTACH KARABINERS TO REAR MAIN FRAME OF THE WHEELCHAIR TO CREATE AN ANGLE OF APPROXIMATELY 45 DEGREES. (FIG B)
4. PULL THE WEBBING THROUGH THE OVER-CENTRE BUCKLE REMOVING THE SLACK. WITH FREE HAND BEGIN TO CLOSE THE BUCKLE (FIG C), ONCE WEBBING IS RETAINED FULLY CLOSE BUCKLE USING BOTH HANDS. FINALLY RE-SECURE FREE WEBBING END ONTO VELCRO STOWAGE POINT.

C. REMOVAL AND STORING

REMOVAL OF THE WHEELCHAIR RESTRAINTS IS THE REVERSAL OF THE INSTALLATION.

STORE THE RESTRAINT SAFELY OFF OF THE FLOOR TO AVOID DAMAGE.

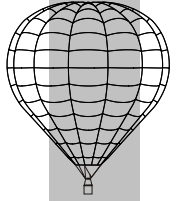

APPENDIX 2
HEADREST
INSTALLATION PROCEDURE

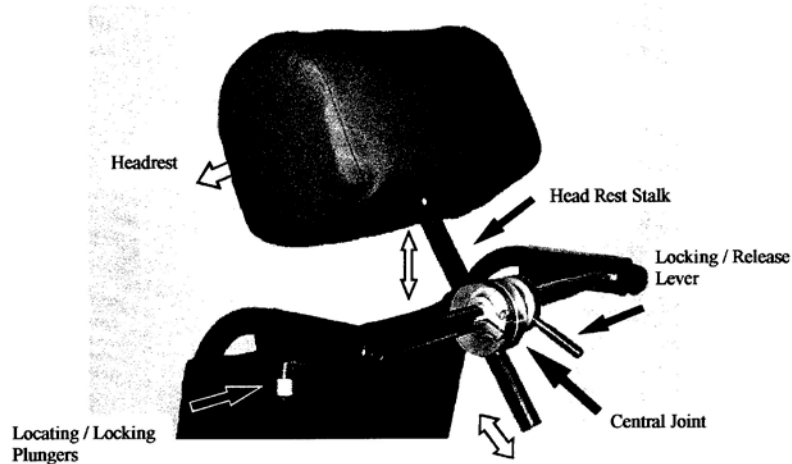

WHEELCHAIR GRIP LIMITATIONS

This headrest is only suitable for use on wheelchairs, manual or electric with two straight handles of the following dimensions.
Straight length 75mm minimum and horizontal within $\pm 20^\circ$

CLAMPING DIAMETER OVER HANDLE AND GRIP (IF FITTED)
MAXIMUM 25.5mm MINIMUM 21.0mm

Distances between centre lines of wheelchair handles,
Adult Model 350mm minimum — 500mm maximum

TO ATTACH TO A WHEELCHAIR

- Unscrew the location / locking plungers
- Slide the open tubes of the headrest frame over the hand grips.
- Secure using the location / locking plungers, by screwing up the knobs on the underside of the tubes. These will usually locate on the wheelchair handgrip, or in some cases, onto the steel tube in front of it.

Side 1/2

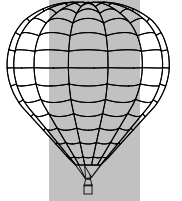
**ADJUSTING THE HEADREST**

- Position the Head Rest centrally onto the wheelchair framework, this may involve slackening the cap head screwed clamp ,on the Central Joint.
- Unlock the Central Joint using the Locking/Release Lever.
- Set the stalk angle using the “peg and hole” adjustment, and the height of the headrest to suit the wheelchair user. When satisfactory lock the Central Joint by re-tightening the Locking/Release Lever.

Note if a greater amount of angular rotation is required, it is achieved by slackening the cap head screw, on the Central Joint, rotating it and then re-locking.

- Finally the headrest itself can pivot slightly to suit the user preference.

If the headrest is permanently fitted to a wheelchair, periodically check to ensure its location onto the handgrips is sound.

NOTE

The adjustment scope of the Headrest will allow it to fit safely on a majority of wheelchairs, but in case of doubt, contacting the wheelchair manufacturer is recommended.

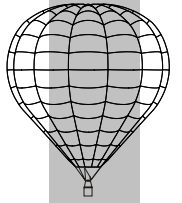

APPENDIX 3

INSTALLATION INSTRUCTIONS

FITTING THE HARNESS

1. Insert the reels into the rail, ensuring that the yellow plungers are to the rear and that the reel with the buckle is on the left.
2. Pull up the webbing on each inertia reel and take across the wheelchair passenger to form a lap and shoulder belt on each side.
3. Fix the tongue into the buckle and position the buckle onto the occupant so that the belt fits over the pelvis.
4. Relieve the load slightly on both shoulders by raising the webbing above the shoulder and applying the Comfort Clips on each reel.
5. Bring the cross strap up until it is at the level of the occupants shoulder blade, using the Velcro attach the strap around the other shoulder strap to ensure that the harness stays in position.

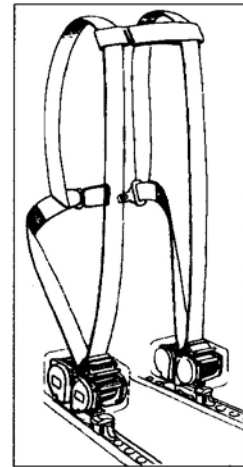
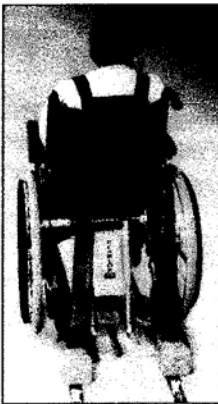

REMOVING AND STORING

1. Undo the Comfort Clips and release the bracing strap.
2. Release the buckle and tongue and remove from the occupant allowing the webbing to retract evenly into the reels.
3. Store the harness safely off the floor to avoid damage and so that it can not become a projectile in an accident.